

NEW

Thin Profile Brushless Motors

with integrated Speed Controller
and 12 Bit Encoder/Interface

0,16 mNm

Series 2209T005B SC ...

Drive	2209 T	12 Bit	
Operating voltage	U _{DD}	2,7 ... 5,5	Volt
Standby current @ U _{DD} = 5V	I _{DD 0}	12	mA
Max. power consumption (start-up) @ U _{DD} = 5V	I _{DD max}	90	mA
Speed control accuracy ¹⁾		0,02	%
Stall torque	M _H	0,16	mNm
Angular acceleration	α _{max}	0,4	·10 ³ rad/s ²
Operating temperature range		-20 ... +85	°C
Shaft bearing		ball bearings, preloaded	
Shaft play:			
– radial		0,011	mm
Shaft load max.:			
– radial at 5 000 rpm (1,5 mm from bearing)		0,6	N
– axial at 5 000 rpm (axial push-on only)		1	N
– axial at standstill (axial push-on only)		1	N
Housing material		aluminium	
Weight		9,7	g
Integrated motor			
Terminal resistance (internal)	R	70	Ω
Speed constant	k _n	4 675	rpm/V
Back-EMF constant	k _E	0,214	mV/rpm
Torque constant	k _M	2,043	mNm/A
Current constant	k _I	0,49	A/mNm
Slope of n-M curve	Δn/ΔM	160 216	rpm/mNm
Mechanical time constant	τ _m	3 926	ms
Rotor inertia	J	2,34	gcm ²
Recommended values - mathematically independent of each other			
Speed up to	n _{e max.}	10 000	rpm
Torque up to	M _{e max.}	0,16	mNm
Thermal current up to	I _{e max.}	0,09	A

¹⁾ @ U_{DD} = 5V; n = 2 000rpm; J_{Last} = 17cm²

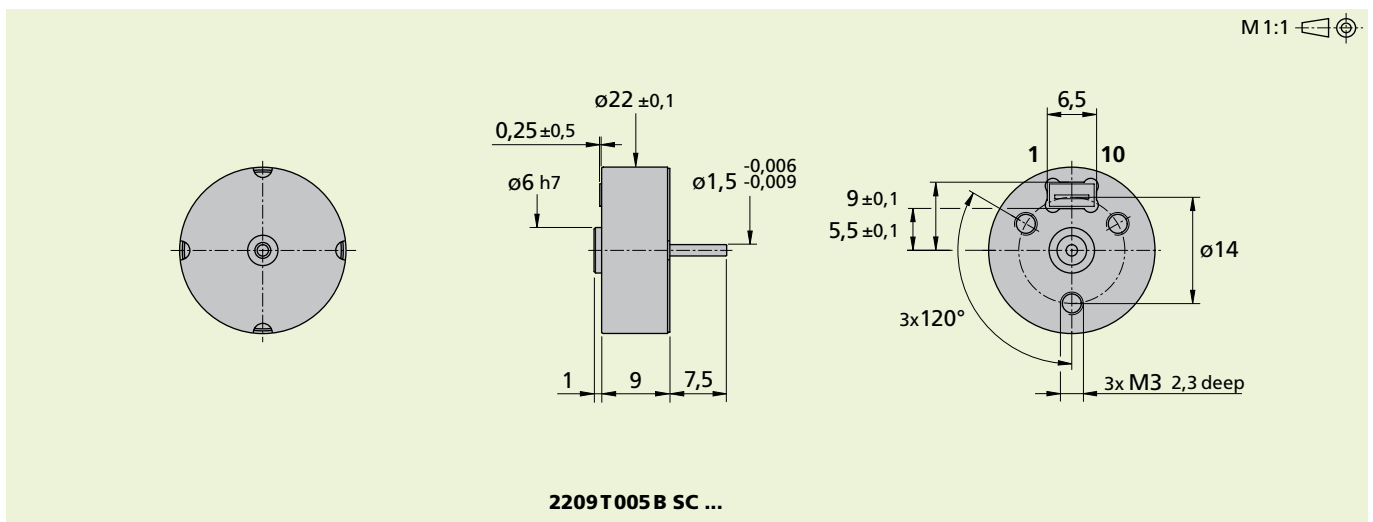

Integrated position regulator		12 Bit	
Steps per revolution		1 024	steps/360°
Regulator type		PID/PD	
Recovery range without step loss		± 22,5	°

Integrated encoder		12 Bit	
Resolution		12	Bit
Precision		0,5	°
Reproducibility		2	LSB
Index impulse/revolution (quadrature)		4	pulses/360°
Absolut values margin		90	°

General information

A high-resolution encoder, a position regulator and an electronically commuted flat motor (penny-motor) are integrated into the 2209T005B SC 12 Bit.

This Drive System with integrated electronics performs the following functions:

- Position regulation:**
 Moving into positions with a resolution of 1/1024 per revolution. The target position is specified via a timing circuit. The position moves on one step per impulse. The regulator is set internally, but can be modified to customer requirements as a PID regulator.
- Speed regulation with outstanding synchronism:**
 In position-regulated mode, a very precise synchronism can be achieved by applying an even cycle. Depending on the rotation inertia, a synchronism of up to 0.02% can be achieved.
- Integrated encoder:**
 The position of the rotor is determined via the integrated encoder (actual value sensor) and used internally for regulation and sinus commutation. The encoder signals can be used externally via an interface. The signal is available as a quadrature signal or via the serial interface (like an I²C bus but 10 not 8 bits are transmitted). The system switches between the two types with a special input.

Various inputs and outputs are available:

- Using the "quadrature/serial" input, it is possible to set whether the encoder signal is output as a quadrature signal or via the serial interface.
- At the outputs "Qa" and "Qb", if the quadrature signal is selected, a 90° phase-shifted output signal is available. The index signal emits a pulse every 90° of a rotation (see diagram).
- The absolute value of the encoder can be read out via the serial interface.
- The direction of rotation of the motor can be changed using the "Direction" input. If the "Low" Signal is set, the drive turns anti-clockwise. If the input is not switched on, it is set to "High" via an internal pull-up resistance and the drive turns clockwise.
- The drive can be operated like a step motor using the "Clock" input: every time the flank of the input signal rises, the rotor is turned further by one position.
- If a very good synchronism is to be achieved, the "Clock" can be provided with a continuous cycle signal. The cycle of the required speed can be created directly, a ramp is not necessary, since the integrated electronic system takes over the start-up of the motor.

Output signals/ Circuit diagram / Connector information

Output signals

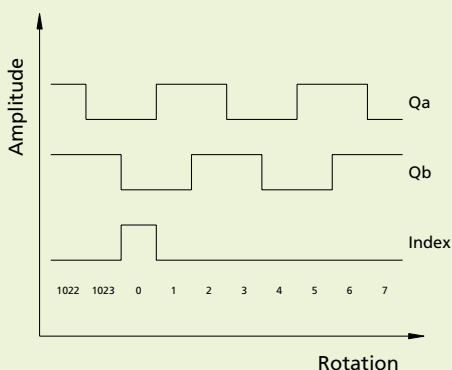

Connection diagramm

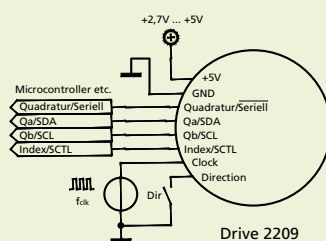

Plug connection

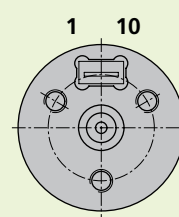

Connection

No.	Function
1	U _{DD}
2	GND
3	Quadratur / Serial
4	(reserved)
5	(reserved)
6	Qa / SDA
7	Qb / SCL
8	Index / SCTL
9	Clock
10	Direction

Caution:
Incorrect lead connection will damage the motor electronics!