

(RoHS) RoHS-Compliant
Brushless DC Motor and Driver Package
with Digital Operator

BLF Series

30 W/60 W/120 W

The **BLF** Series Brushless DC Motor and driver package adopts a brand new design for its motor, gearhead and driver. In addition to achieving a maximum motor speed of 4000 r/min, the **BLF** Series provides easy operation via a detachable digital operator and offers wide-ranging functions and motor variations to meet the increasingly diverse needs of manufacturers.



New **BLF** Series

The **BLF** Series combines the attractive features of a brushless DC motor, such as compact size, high output, flat torque, excellent speed stability and energy-saving design, with exciting new enhancements that include a wider speed range and multi-speed operation. Using the digital operator, you can draw the maximum performance out of this feature-rich **BLF** Series with ease.

Digital Operator

Making the user-friendly driver even easier to use

The driver of the **BLF** Series comes standard with a digital operator that can be used as a data setting unit and display. Using the operation keys, you can input speed settings digitally in no time. The digital operator also provides full driver functions, such as:

- Three speed display modes
- Multi-speed operation using up to eight speeds
- Four speed setting methods
- Various protection functions



A Wide Speed Control Range From **80 to 4000 r/min**

The maximum motor speed of the **BLF** Series is 4000 r/min, which is higher than the 3000 r/min achieved by our previous products. The speed control range has also expanded to cover velocities from 80 to 4000 r/min (speed ratio of 1:50; measured at the motor shaft), thus allowing you to program operations at various speeds from low to high.

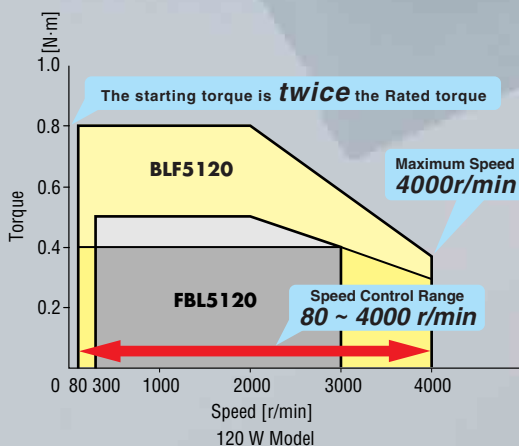

Slim, Yet Powerful Design

A slim body and high output are two key features of a brushless DC motor. The **BLF** Series does not disappoint the users expecting these attributes. From its space-saving compact body with a frame size of 90 mm and overall motor length of 60 mm, the **BLF** Series produces a high output of 120 W.

Long-life Gearhead

The gearhead of the **BLF** Series is designed for use with high-speed motors, but its rated life is 10,000 hours at 3000 r/min, almost twice the life of conventional gearheads.

IP65* Protection

The motor (excluding the mounting surface of the round shaft type and the connector) and digital operator (when an optional remote-control kit is used) provide a high level of protection conforming to IP65. It means you can use the **BLF** Series in locations where the unit may come in contact with water.

* The **BLF** Series is not designed for washing directly in water or use in an environment where the unit constantly receives water splashes. The protection class of the driver is IP20.

Easy Wiring

- A maximum motor/driver wiring distance of 20 m

By separating the motor cable and signal cable, the **BLF** Series is less vulnerable to noise and thus allows for an extension of the motor/driver wiring distance to a maximum of 20 m. [Select an optional connection cable set from among the eight lengths of 1 to 20 m]

- Uses a terminal block for driver connection

The driver-end of each cable has a terminal block, instead of a connector, to make it easy to wire the cable into a distribution board, control panel, etc.

RoHS RoHS-Compliant

The **BLF** Series conforms to the RoHS Directive that prohibits the use of six chemical substances including lead and cadmium.

RoHS (Restriction of Hazardous Substances) Directive:

Directive on restriction of the use of certain hazardous substances in electrical and electronic equipment (2002/95/EC).

The RoHS Directive prohibits the use of six chemical substances in electrical and electronic products sold in EU member states on or after July 1, 2006. The six controlled substances are: lead, hexavalent chromium, cadmium, mercury and two specific brominated flame-retardants (PBB and PBDE).

VEXTA

A Wide Lineup

The **BLF** Series consists of three types, including two combination types integrated with a parallel shaft gearhead or a hollow shaft flat gearhead, and one round shaft type. All models come in three output levels of 30, 60 and 120 W, and the frame sizes are also selectable from three choices. Mix and match to select the best combination meeting the specification and application requirements of your equipment.

Combination Type Parallel Shaft Gearhead



- Frame Size
 - 60 mm
 - 80 mm
 - 90 mm
- Output Power
 - 30 W
 - 60 W
 - 120 W
- Power Supply Voltage
 - Single-Phase 200–240 V

For the parallel shaft gearhead with frame size of 90 mm, the gearhead output shaft has a tapped hole on its shaft end.

Combination Type Hollow Shaft Flat Gearhead



- Frame Size
 - 60 mm
 - 80 mm
 - 90 mm
- Output Power
 - 30 W
 - 60 W
 - 120 W
- Power Supply Voltage
 - Single-Phase 200–240 V

Round Shaft Type



- Frame Size
 - 60 mm
 - 80 mm
 - 90 mm
- Output Power
 - 30 W
 - 60 W
 - 120 W
- Power Supply Voltage
 - Single-Phase 200–240 V

Achieving High Function with Easy Operation

Digital Operator – Enhancing the Ease of Operation

The driver of the **BLF** Series comes standard with a detachable digital operator. You can perform various settings and operations using the six operation keys on the digital operator.

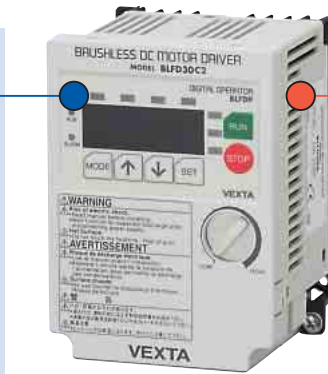

High-Function Driver

The driver offers new functions not available with conventional brushless DC motors, such as the multi-speed operation function and speed teaching function.

Different Speed Display Modes

The **BLF** Series supports three speed display modes. Choose a mode that best suits your application.

Motor speed display [r/min]

In this mode, the speed of the motor shaft or gear output shaft is displayed.

Conveyor speed display [m/min]

In this mode, the transfer speed of the work on a conveyor, etc., is displayed.

Load factor display [%]

In this mode, the actual load is displayed as a percentage of the rated load being 100%.*

* A maximum error of approx. 20% may generate when the motor is operated at the rated speed under the rated load.

Detachable Digital Operator

The digital operator, which serves as both a data setting unit and a display, can be detached from the driver and used at a location as far as 5 m away using an optional remote-control kit. Use the digital operator as a handy operation unit or a display outside the distribution panel. (The digital operator conforms to IP65 when the remote-control kit is used.)



Multi-Speed Operation Using Up to Eight Speeds

The **BLF** Series lets you program multi-speed operations. Up to eight speeds can be set and registered, and selected freely using external signals.

Speeds can be set in units of 1 r/min on the digital operator and a different acceleration/deceleration time can be set for each speed, thus allowing creation of diverse profiles for various operation patterns of your equipment.

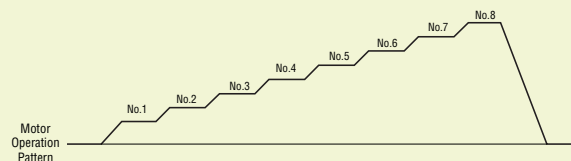

Operation Data	M0 Input	M1 Input	M2 Input	Speed Setting Method
No. 1	OFF	OFF	OFF	Internal Potentiometer/Digital Operator
No. 2	ON	OFF	OFF	External Potentiometer/Digital Operator
No. 3	OFF	ON	OFF	Digital Operator
No. 4	ON	ON	OFF	Digital Operator
No. 5	OFF	OFF	ON	Digital Operator
No. 6	ON	OFF	ON	Digital Operator
No. 7	OFF	ON	ON	Digital Operator
No. 8	ON	ON	ON	Digital Operator

Speed Teaching Function

The speed teaching function allows you to set speeds by physically operating the motor. It's an easy way to set speeds regardless of the mechanism of your equipment.

Various Protection Functions

The **BLF** Series detects various motor and driver errors such as overload, overvoltage, low-voltage, missing phase, overspeed, overcurrent, EEPROM error, CPU error, operation error and external error. Upon detection of an error, the driver will immediately stop the motor and output an alarm signal.

Switchable Sink/Source Inputs

Select the sink mode or source mode for the input terminals. You can change the setting at any time.

Four Speed Setting Methods to Match Different Conditions of Use

The **BLF** Series lets you control speeds using one of four methods. Select the internal potentiometer, digital operator, external potentiometer or external DC voltage according to the condition in which your equipment is used. (Details of each speed setting method → Page 22)

① Internal Potentiometer

Turn the built-in speed setting knob on the driver to set a desired speed.

③ External Potentiometer

You can use an optional external potentiometer to set speeds at a location away from the driver.

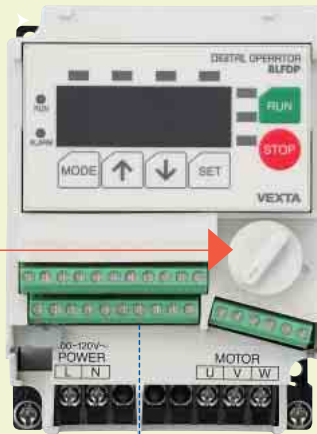

② Digital Operator

Directly enter a desired value using the operation keys on the digital operator located on the driver's front panel. Speeds can be set in units of 1 r/min using the digital operator.

④ External DC Voltage

Speeds can be set by connecting an external DC power supply and supplying DC voltage to the driver. The **BLF** Series supports two DC power supplies of 5 VDC and 10 VDC.

External DC power supply

■ Safety Standards and CE Marking

Model	Standards	Certification Body	Standards File No.	CE Marking
Motor	UL 1004	UL	E62327	Low Voltage Directives EMC Directives
	CSA C22.2 No.100			
	EN 60950-1			
	EN 60034-1			
	EN 60034-5			
IEC 60664-1	Conforms to EN/IEC Standards			
Driver	UL 508C	UL	E171462	
	CSA C22.2 No.14			
	EN 60950-1			
	EN 50178			

● Compliance Conditions under EN Standards

- Incorporation in equipment
- Overvoltage category Motor: III Driver: III
- Pollution degree Motor: 3 Driver: 2
- Electrical shock protection Motor: Class I equipment Driver: Class I equipment

● Use Conditions

- Protective earth: The motor and driver have been designed and evaluated as Class I equipment. Therefore, measures are needed to protect against electrical shock, such as providing a protective grounding or incorporating the motor/driver in the equipment to prevent contact with the bare hands.
- Power supply: The motor and driver have been designed and evaluated under Overvoltage Category III.
- Surroundings: The motor has been designed and evaluated in an environment with a pollution degree 3, and the driver has been designed and evaluated in an environment with pollution degree 2. When using the driver in an environment with pollution degree 3, it must be protected within an IP54 enclosure.

- EMC: The EMC value changes according to the wiring and layout. Therefore, the final EMC level must be checked with the motor/driver incorporated in the user's equipment. If you require EMC data of this product, please contact your nearest Oriental Motor office.

● Applicable Standards

- EMI

Emission Tests:	EN 61000-6-4
Radiated Emission Test:	EN 55011
Conducted Emission Test:	EN 55011
- EMS

Immunity Tests:	EN 61000-6-2
Electrostatic Discharge Immunity Test:	IEC 61000-4-2
Radiation Field Immunity Test:	IEC 61000-4-3
Fast Transient/Burst Immunity Test:	IEC 61000-4-4
Surge Immunity Test:	IEC 61000-4-5
Conductive Noise Immunity Test:	IEC 61000-4-6
Power Frequency Magnetic Field Immunity Test:	IEC 61000-4-8
Voltage Dip Immunity Test:	IEC 61000-4-11
Voltage Interruption Immunity Test:	IEC 61000-4-11

System Configuration

Combination Type – Parallel Shaft Gearhead, Round Shaft Type

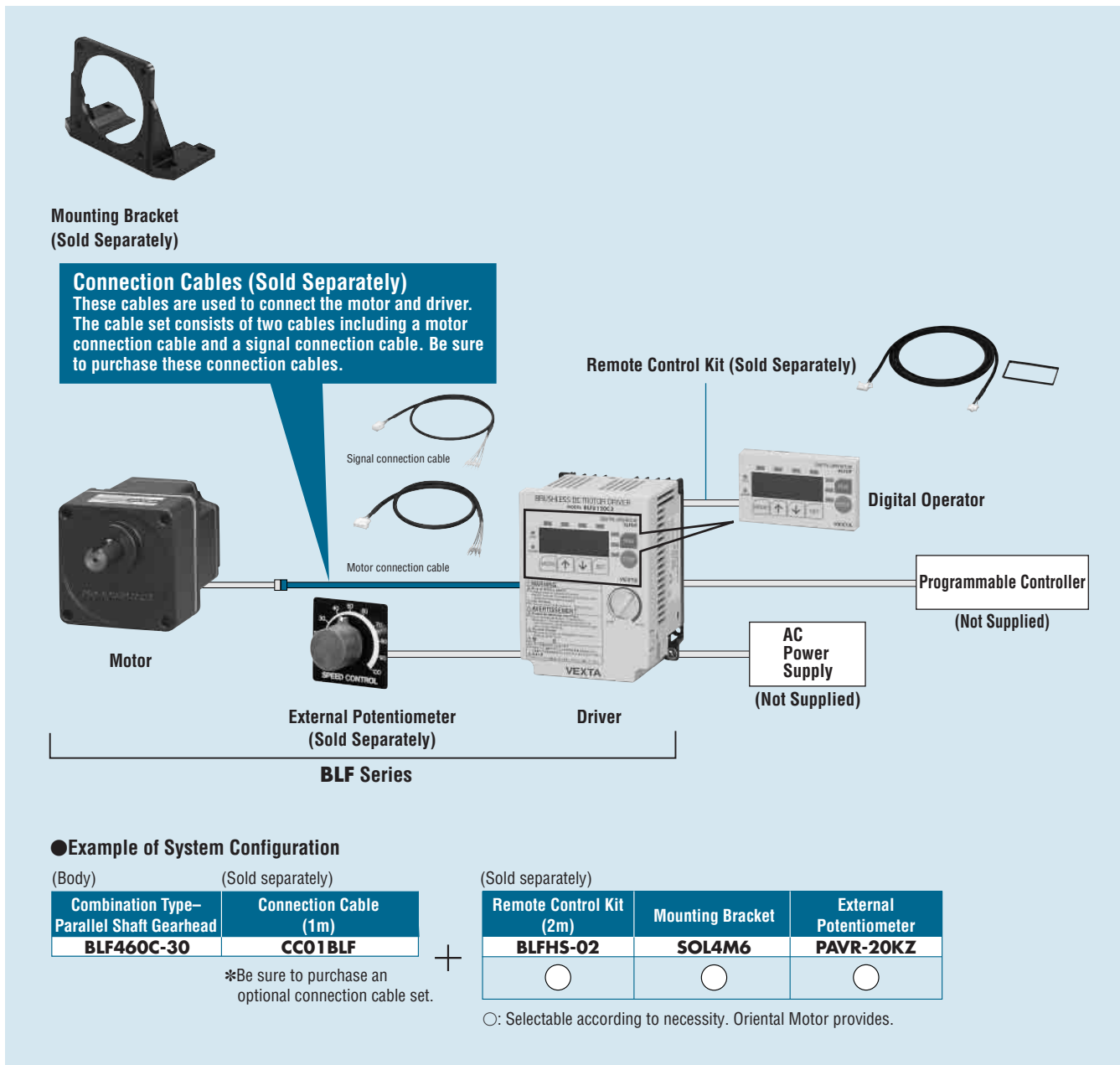

●The system configuration shown is an example. Other combinations are available.

Connection Cables

The **BLF** Series requires two dedicated cables, one for the motor and the other for signals, for connection between the motor and driver. These connection cables are not supplied with the **BLF** Series, so be sure to purchase an optional connection cable set. The optional cable set consists of two cables including a motor connection cable and a signal connection cable. Specify a desired cable length from the eight choices of 1 m to 20 m. → Page 26

● **Combination Type –Hollow Shaft Flat Gearhead**

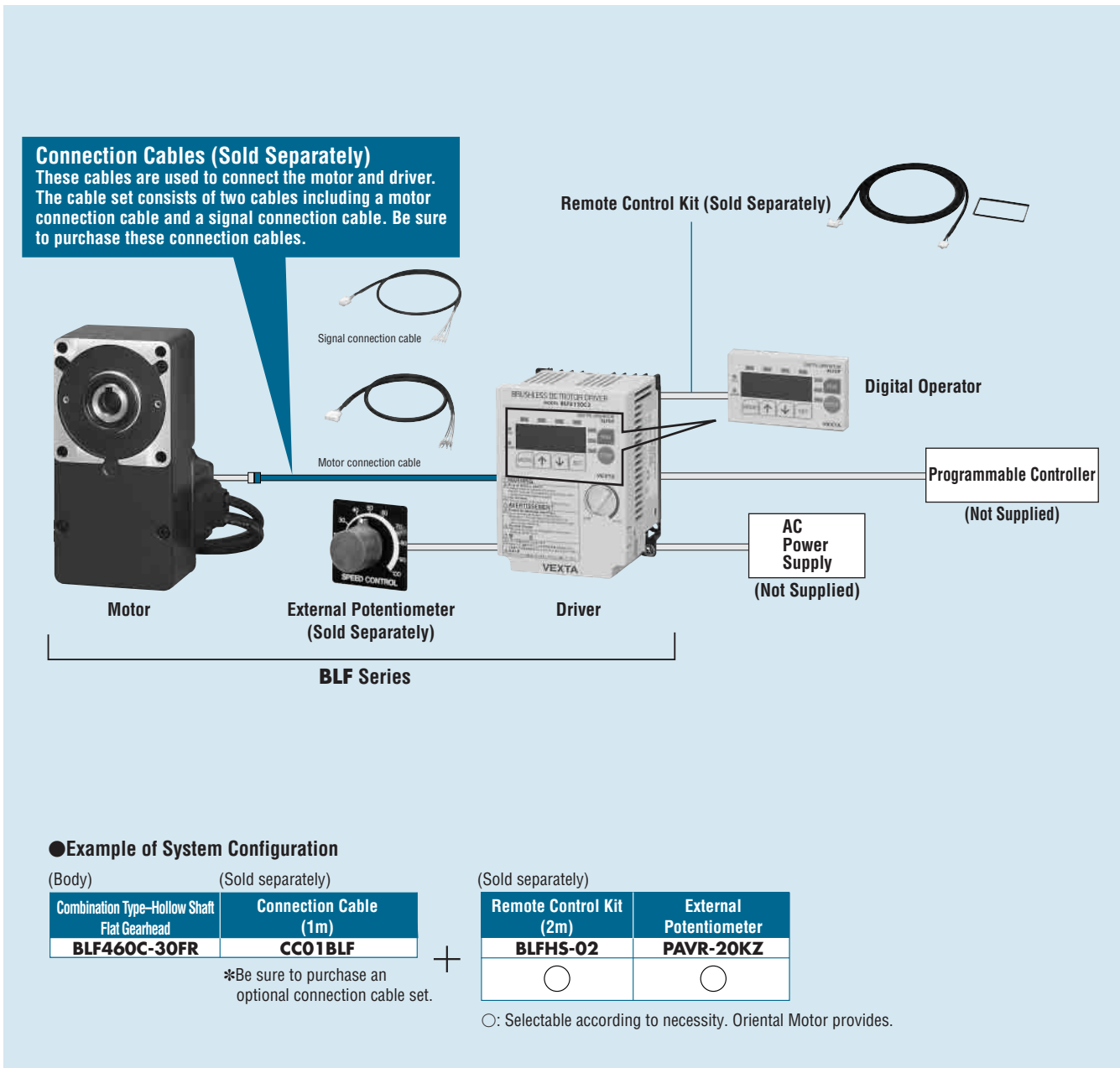

● The system configuration shown is an example. Other combinations are available.

■ **Connection Cables**

The **BLF Series** requires two dedicated cables, one for the motor and the other for signals, for connection between the motor and driver. These connection cables are not supplied with the **BLF Series**, so be sure to purchase an optional connection cable set. The optional cable set consists of two cables including a motor connection cable and a signal connection cable. Specify a desired cable length from the eight choices of 1 m to 20 m. → Page 26

Product Number Code

BLF **2** **30** **C** - **5** **FR**

① ② ③ ④ ⑤ ⑥

①	Series	BLF Series
②	Motor Frame Size	2 : 60 mm sq. 4 : 80 mm sq. 5 : 90 mm sq.
③	Output Power	30 : 30 W 60 : 60 W 120 : 120 W
④	Voltage	C : Single-Phase 200–240 VAC
⑤	Gear Ratio or Shaft Type	Number : Gear Ratio A : Round Shaft Type
⑥	Gearhead Type of Combination Type	None : Parallel Shaft Gearhead FR : Hollow Shaft Flat Gearhead

Product Line

Combination Type (Pre-assembled Gearmotor)

The combination type (pre-assembled gearmotor) come with the motor and its dedicated gearhead already assembled. This simplifies installation in equipment. Motors and gearheads are also available separately so they can be on hand to make changes or repair.

Combination Type –Parallel Shaft Gearhead

Output Power	Voltage	Model	Gear Ratio	Motor/Driver Combination		
				Motor Model	Gearhead Model	Driver Model
30 W	Single-Phase 200–240 VAC	BLF230C -□	5, 10, 15, 20, 30, 50, 100, 200	BLFM230-GFS	GFS2G□	BLFD30C2
60 W	Single-Phase 200–240 VAC	BLF460C -□	5, 10, 15, 20, 30, 50, 100, 200	BLFM460-GFS	GFS4G□	BLFD60C2
120 W	Single-Phase 200–240 VAC	BLF5120C -□	5, 10, 15, 20, 30, 50, 100, 200	BLFM5120-GFS	GFS5G□	BLFD120C2

●Enter the gear ratio in the box (□) within the model name and gearhead model name.

Combination Type –Hollow Shaft Flat Gearhead

Output Power	Voltage	Model	Gear Ratio	Motor/Driver Combination		
				Motor Model	Gearhead Model	Driver Model
30 W	Single-Phase 200–240 VAC	BLF230C -□ FR	5, 10, 15, 20, 30, 50, 100, 200	BLFM230-GFS	GFS2G□FR	BLFD30C2
60 W	Single-Phase 200–240 VAC	BLF460C -□ FR	5, 10, 15, 20, 30, 50, 100, 200	BLFM460-GFS	GFS4G□FR	BLFD60C2
120 W	Single-Phase 200–240 VAC	BLF5120C -□ FR	5, 10, 15, 20, 30, 50, 100, 200	BLFM5120-GFS	GFS5G□FR	BLFD120C2

●Enter the gear ratio in the box (□) within the model name and gearhead model name.

● Round Shaft Type

Output Power	Voltage	Model	Motor/Driver Combination	
			Motor Model	Driver Model
30 W	Single-Phase 200–240 VAC	BLF230C-A	BLFM230-A	BLFD30C2
60 W	Single-Phase 200–240 VAC	BLF460C-A	BLFM460-A	BLFD60C2
120 W	Single-Phase 200–240 VAC	BLF5120C-A	BLFM5120-A	BLFD120C2

● Pinion Shaft Type

Output Power	Voltage	Model	Motor/Driver Combination	
			Motor Model	Driver Model
30 W	Single-Phase 200–240 VAC	BLF230C-GFS	BLFM230-GFS	BLFD30C2
60 W	Single-Phase 200–240 VAC	BLF460C-GFS	BLFM460-GFS	BLFD60C2
120 W	Single-Phase 200–240 VAC	BLF5120C-GFS	BLFM5120-GFS	BLFD120C2

● Gearheads

◇ Parallel Shaft Gearhead

Model	Gear Ratio
GFS2G <input type="checkbox"/>	5, 10, 15, 20, 30, 50, 100, 200
GFS4G <input type="checkbox"/>	
GFS5G <input type="checkbox"/>	

● Enter the gear ratio in the box (□) within the model name.

◇ Hollow Shaft Flat Gearhead

Model	Gear Ratio
GFS2G <input type="checkbox"/> FR	5, 10, 15, 20, 30, 50, 100, 200
GFS4G <input type="checkbox"/> FR	
GFS5G <input type="checkbox"/> FR	

● Enter the gear ratio in the box (□) within the model name.

● Connection Cables (Sold Separately)

◇ Cable Set

Length	Model
1 m	CC01BLF
2 m	CC02BLF
3 m	CC03BLF
5 m	CC05BLF
7 m	CC07BLF
10 m	CC10BLF
15 m	CC15BLF
20 m	CC20BLF

● The **BLF** Series requires two dedicated cables, one for the motor and the other for signals, for connection between the motor and driver. These connection cables are not supplied with the **BLF** Series, so be sure to purchase an optional connection cable set. The optional cable set consists of two cables including a motor connection cable and a signal connection cable.

Specifications

RoHS

Motor:  / Driver: 

Combination Type - Parallel Shaft Gearhead		BLF230C-□	BLF460C-□	BLF5120C-□	
Model	Combination Type - Hollow Shaft Flat Gearhead	BLF230C-□FR	BLF460C-□FR	BLF5120C-□FR	
	Round Shaft Type	BLF230C-A	BLF460C-A	BLF5120C-A	
	Rated Output Power (Continuous)	W	30	60	120
Power Source	Rated Voltage	V	Single-Phase 200~240 ±10%		
	Rated Frequency	Hz	50/60 ±5%		
	Rated Input Current	A	0.8	1.2	2.0
	Maximum Input Current	A	1.7	3.0	4.5
Rated Torque	N·m	0.1	0.2	0.4	
Starting Torque	N·m	0.2	0.4	0.8	
Rated Speed	r/min	3000			
Speed Control Range	r/min	80~4000			
Permissible Load Inertia*1	J kg·m ²	1.8×10 ⁻⁴	3.75×10 ⁻⁴	5.6×10 ⁻⁴	
Speed Regulation*2 (Settings from the digital operator)	Load	±0.2% maximum (0~Rated torque, at rated speed, at rated voltage, at normal ambient temperature)			
	Voltage	±0.2% maximum (Rated voltage ±10%, at rated speed, with no load, at normal ambient temperature)			
	Temperature	±0.2% maximum (0~50°C, at rated speed, with no load, at rated voltage)			

*1 The permissible load inertia specified above is only applicable for round shaft models. Permissible load inertia for combination type → Page 13

*2 Speed regulation values vary depending on the speed setting method.

Settings from internal potentiometer; Load: ±0.5% maximum, Voltage: ±0.5% maximum, Temperature: ±0.5% maximum

Settings from external potentiometer or external DC voltage; Load: ±0.5% maximum, Voltage: ±0.5% maximum, Temperature: ±0.5% maximum

● Enter the gear ratio in the box (□) within the model name.

● The value for each item is for the motor only.

Common Specifications

Item	Specification
Speed Setting Method	Select one of the following methods: 1. Set using the internal potentiometer 2. Set using the digital operator: Up to eight speeds (Speeds can be set in units of r/min only when using the digital operator.) 3. Set using an optional external potentiometer: PAVR-20KZ (20 kΩ, 1/4 W) 4. Set using external DC voltage: 0 to 5 VDC or 0 to 10 VDC
Acceleration/Deceleration Time (at 3000 r/min)	0.2 to 15 seconds (factory setting: 0.5 second). Up to eight speeds using the digital operator
Input Signals (In the remote mode)	Photocoupler input mode: Input resistance 3.3 kΩ, Voltage with no power supply: 14 VDC±10% (Internal Power Source) Connectable external voltage: 24 VDC±10% Source input or Sink input / 2-wire input mode (factory setting) or 3-wire input mode CW [START/STOP] input, CCW [RUN/BRAKE] input, STOP-MODE [CW/CCW] input, speed-data selection input, alarm reset input, external error input The names in [] apply in the 3-wire input mode.
Output Signals	Open collector output: 4.5 to 26.4 VDC or less, 10 mA or less (speed output: 5 mA or more/10 mA or less) Speed output (30 pulses/revolution), alarm output 1, alarm output 2
Protection Functions*	Upon actuation of any of the following protection functions, the driver will output an alarm signal and cause the motor to decelerate to a stop (the motor will stop instantaneously in the event of an external error): ● Overload protection function: A load exceeding the rated torque was applied to the motor for approx. 5 seconds or more. ● Overvoltage protection function: The driver voltage exceeded 240 VAC by approx. 20% or more. A gravitational operation was performed or a load exceeding the allowable load inertia was driven. ● Low-voltage protection function: The driver voltage dropped to approx. 40% or more below 200 VAC. ● Missing-phase protection function: An error was detected in the signals received from the motor due to poor connection or breakage of the signal cable, etc. ● Overspeed protection function: The speed of the motor shaft exceeded approx. 4800 r/min. ● Overcurrent protection function: An excessive current flowed through the driver due to a ground fault, etc. ● CPU error, EEPROM error, external error or operation error
Motor Insulation Class	Class E (120°C)
Time Rating	Continuous

* With the **BLF Series**, the motor speed cannot be controlled in a gravitational operation or other application where the motor shaft is turned by the load. When a load exceeding the allowable load inertia is driven or a gravitational operation is performed, the overvoltage protection function will actuate to cause the motor to decelerate to a stop.

General Specifications (After rated operation under normal ambient temperature and humidity.)

Item	Motor	Driver
Insulation Resistance	100MΩ or more when 500 VDC megger is applied between the windings and the frame.	100MΩ or more when 500 VDC megger is applied between the power supply input terminal and the Protective Earth terminal, between the power supply input terminal and I/O terminal.
Dielectric Strength	Sufficient to withstand 1.5 kV at 50 Hz applied between the windings and the frame for 1 minute .	Sufficient to withstand 1.8 kV (3 kV) at 50 Hz applied between the power supply input terminal and Protective Earth terminal (I/O terminal) for one minute.
Operating Environmental Conditions	Ambient Temperature	0°C~50°C, nonfreezing
	Ambient Humidity	85 % maximum, noncondensing
	Atmosphere	No corrosive gas or dust
Degree of Protection	IP 65 (excluding the motor-installation surface of the round shaft type and the connector .)	Driver: IP 20 (In the cabinet) Digital Operator: IP 65 (Optional remote operation kit is used.)

Note:

For round shaft types, please attach to the following sizes of heat sink (material: aluminum) to maintain a maximum motor housing temperature of 90°C.

BLF230C-A: 115 mm × 115 mm, 5 mm thick

BLF460C-A: 135 mm × 135 mm, 5 mm thick

BLF5120C-A: 165 mm × 165 mm, 5 mm thick

Gearmotor – Torque Table

Combination Type –Parallel Shaft Gearhead

Unit=N·m

Model	Gear Ratio	Motor Speed	5	10	15	20	30	50	100	200	
			80 r/min	16	8	5.3	4	2.7	1.6	0.8	0.4
			3000 r/min	600	300	200	150	100	60	30	15
BLF230C-□	at 80~3000 r/min	4000 r/min	800	400	267	200	133	80	40	20	
		at 80~3000 r/min	0.45	0.9	1.4	1.8	2.6	4.3	6	6	
BLF460C-□	at 80~3000 r/min	at 4000 r/min	0.34	0.68	1	1.4	1.9	3.2	5.4	5.4	
		at 80~3000 r/min	0.9	1.8	2.7	3.6	5.2	8.6	16	16	
BLF5120C-□	at 80~3000 r/min	at 4000 r/min	0.68	1.4	2	2.7	3.9	6.5	12.9	14	
		at 80~3000 r/min	1.8	3.6	5.4	7.2	10.3	17.2	30	30	
BLF5120C-□	at 80~3000 r/min	at 4000 r/min	1.4	2.7	4.1	5.4	7.7	12.9	25.8	27	

● Enter the gear ratio in the box (□) within the model name.

● A colored background indicates gear shaft rotation in the same direction as the motor shaft; a white background indicates rotation in the opposite direction.

Combination Type –Hollow Shaft Flat Gearhead

Unit=N·m

Model	Gear Ratio	Motor Speed	5	10	15	20	30	50	100	200	
			80 r/min	16	8	5.3	4	2.7	1.6	0.8	0.4
			3000 r/min	600	300	200	150	100	60	30	15
BLF230C-□FR	at 80~3000 r/min	4000 r/min	800	400	267	200	133	80	40	20	
		at 80~3000 r/min	0.4	0.85	1.3	1.7	2.6	4.3	8.5	17	
BLF460C-□FR	at 80~3000 r/min	at 4000 r/min	0.3	0.64	0.96	1.3	1.9	3.2	6.4	12.8	
		at 80~3000 r/min	0.85	1.7	2.6	3.4	5.1	8.5	17	34	
BLF5120C-□FR	at 80~3000 r/min	at 4000 r/min	0.64	1.3	1.9	2.6	3.8	6.4	12.8	25.5	
		at 80~3000 r/min	1.7	3.4	5.1	6.8	10.2	17	34	68	
BLF5120C-□FR	at 80~3000 r/min	at 4000 r/min	1.3	2.6	3.8	5.1	7.7	12.8	25.5	51	

● Enter the gear ratio in the box (□) within the model name.

Rotating Direction of the Hollow Shaft Flat Gearhead

The hollow-shaft flat gearhead of the combination type rotates in the direction as shown below, with respect to the direction input from the driver.

Front View

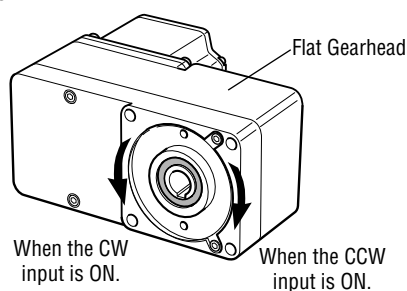

Rear View

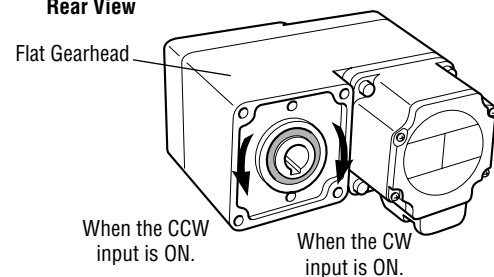

■ Permissible Overhung Load and Permissible Thrust Load

● Combination Type –Parallel Shaft Gearhead

Model	Gear Ratio		Permissible Overhung Load		Permissible Thrust Load N
			10 mm from shaft end N	20 mm from shaft end N	
BLF230C-□	5	80~3000 r/min	100	150	40
		4000 r/min	90	110	
	10, 15, 20	80~3000 r/min	150	200	
		4000 r/min	130	170	
	30, 50, 100, 200	80~3000 r/min	200	300	
		4000 r/min	180	230	
BLF460C-□	5	80~3000 r/min	200	250	100
		4000 r/min	180	220	
	10, 15, 20	80~3000 r/min	300	350	
		4000 r/min	270	330	
	30, 50, 100, 200	80~3000 r/min	450	550	
		4000 r/min	420	500	
BLF5120C-□	5	80~3000 r/min	300	400	150
		4000 r/min	230	300	
	10, 15, 20	80~3000 r/min	400	500	
		4000 r/min	370	430	
	30, 50, 100, 200	80~3000 r/min	500	650	
		4000 r/min	450	550	

● Enter the gear ratio in the box (□) within the model name.

● Combination Type –Hollow Shaft Flat Gearhead

Model	Gear Ratio		Permissible Overhung Load		Permissible Thrust Load N
			10 mm from mounting surface of hollow shaft gearhead N	20 mm from mounting surface of hollow shaft gearhead N	
BLF230C-□FR	5, 10	80~3000 r/min	450	370	200
		4000 r/min	410	330	
	15, 20, 30, 50, 100, 200	80~3000 r/min	500	400	
		4000 r/min	460	370	
BLF460C-□FR	5, 10	80~3000 r/min	800	660	400
		4000 r/min	730	600	
	15, 20, 30, 50, 100, 200	80~3000 r/min	1200	1000	
		4000 r/min	1100	910	
BLF5120C-□FR	5, 10	80~3000 r/min	900	770	500
		4000 r/min	820	700	
	15, 20	80~3000 r/min	1300	1110	
		4000 r/min	1200	1020	
	30, 50, 100, 200	80~3000 r/min	1500	1280	
		4000 r/min	1400	1200	

● Enter the gear ratio in the box (□) within the model name.

● Round Shaft Type

Model	Permissible Overhung Load	
	10 mm from shaft end N	20 mm from shaft end N
BLF230C-A	80	100
BLF460C-A	110	130
BLF5120C-A	150	170

Note:

Avoid thrust as much as possible for the round shaft motors. If thrust load is unavoidable, keep it to no more than half the motor mass.

Permissible Load Inertia J for Combination Type

Combination Type –Parallel Shaft Gearhead

Unit= $\times 10^{-4} \text{ kg} \cdot \text{m}^2$

Model \ Gear Ratio	5	10	15	20	30	50	100	200
BLF230C-□	1.55	6.2	14	24.8	55.8	155	155	155
BLF460C-□	5.5	22	49.5	88	198	550	550	550
BLF5120C-□	25	100	225	400	900	2500	2500	2500

Enter the gear ratio in the box (□) within the model name.

Combination Type –Hollow Shaft Flat Gearhead

Unit= $\times 10^{-4} \text{ kg} \cdot \text{m}^2$

Model \ Gear Ratio	5	10	15	20	30	50	100	200
BLF230C-□FR	1.55	6.2	14	24.8	55.8	155	155	155
BLF460C-□FR	5.5	22	49.5	88	198	550	550	550
BLF5120C-□FR	25	100	225	400	900	2500	2500	2500

Enter the gear ratio in the box (□) within the model name.

Speed – Torque Characteristics

Continuous Duty Region: Continuous operation is possible in this region.

Limited Duty Region: This region is used primarily when accelerating. When a load that exceeds the rated torque is applied continuously for approximately 5 seconds, overload protection is activated and the motor comes to stop.

BLF230C-□/ BLF230C-□FR/ BLF230C-A

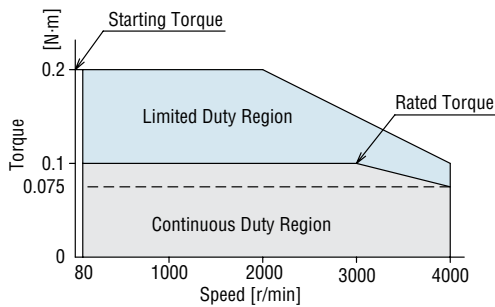

BLF460C-□/ BLF460C-□FR/ BLF460C-A

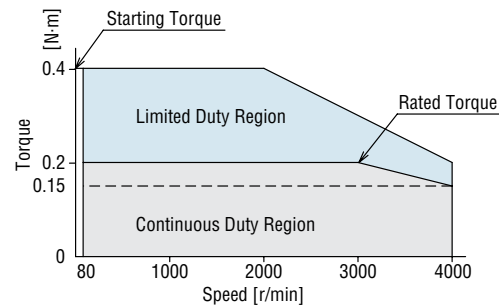

BLF5120C-□/ BLF5120C-□FR/ BLF5120C-A

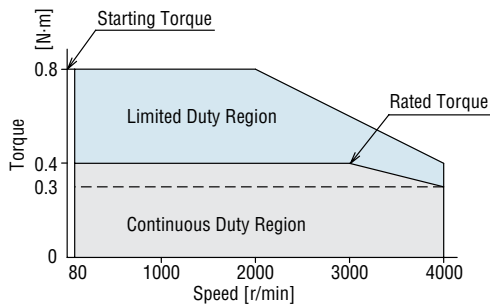

- The characteristics shown above are applicable for the motors only.
- Enter the gear ratio in the box (□) within the model name.

Dimensions unit: mm

Mounting screws are included with the combination type.

● Enter the gear ratio in the box (□) within the model name.

Motor/Parallel Shaft Gearhead

BLF230C-□ (Combination type -Parallel shaft gearhead)

Motor: BLFM230-GFS

Gearhead: GFS2G□

Mass: 1.1 kg

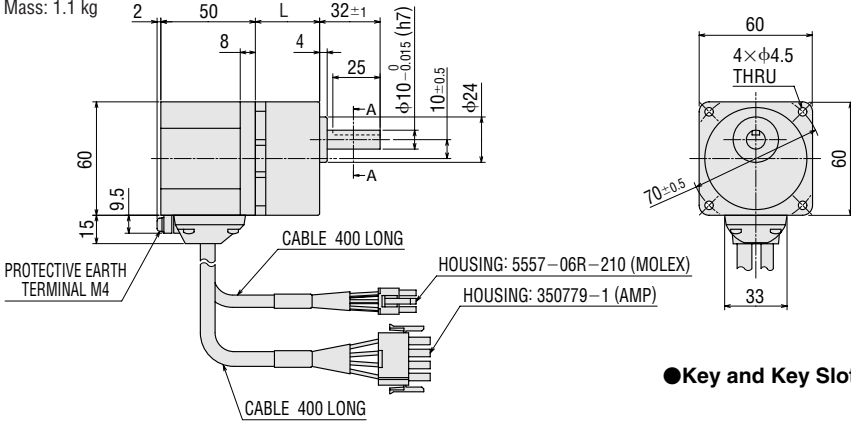

GFS2G5~20:	L=34
GFS2G30~100:	L=38
GFS2G200:	L=43

● **Key and Key Slot** (The key is included with the gearhead.)

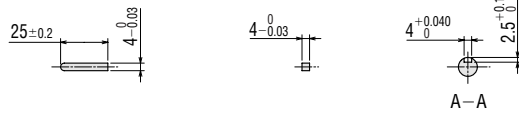

Motor/Hollow Shaft Flat Gearhead

BLF230C-□FR (Combination type -Hollow shaft flat gearhead)

Motor: BLFM230-GFS

Gearhead: GFS2G□FR

Mass: 1.4 kg

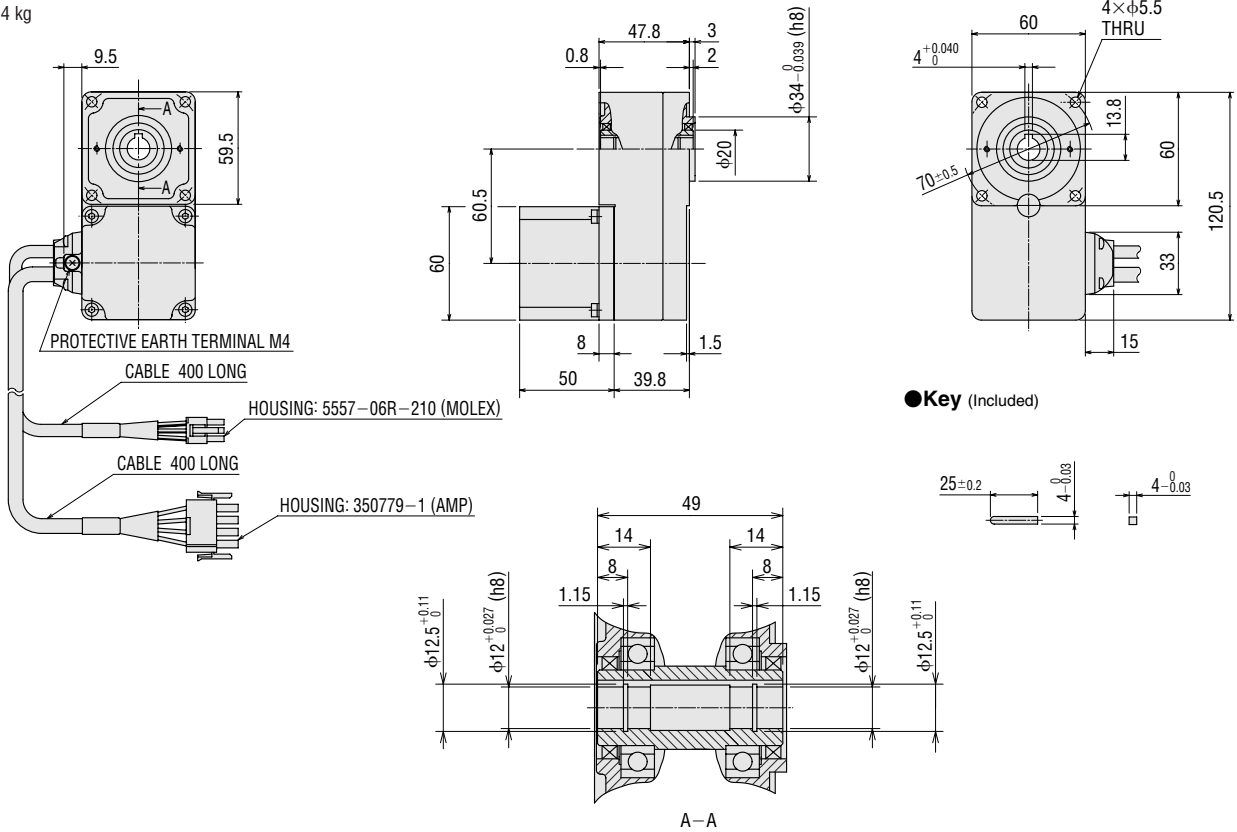

● **Key** (Included)

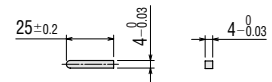

◇ Round Shaft Type

BLF230C-A (Round shaft type)

Motor: BLFM230-A

Mass: 0.6 kg

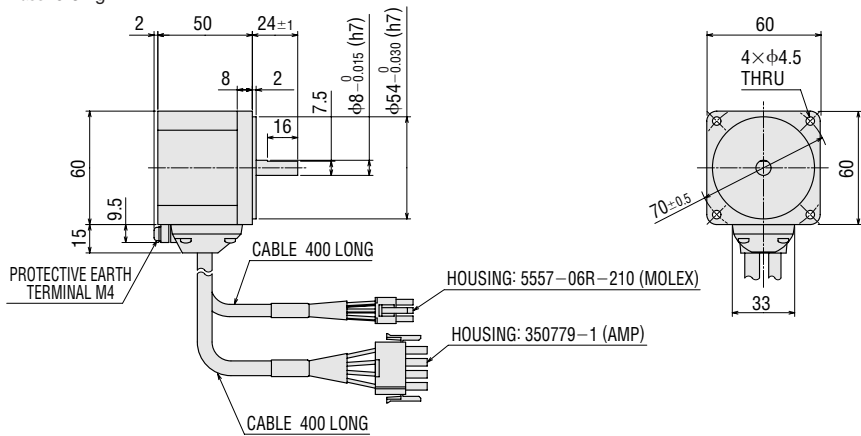

◇ Motor/Parallel Shaft Gearhead

BLF460C-□ (Combination type -Parallel shaft gearhead)

Motor: BLFM460-GFS

Gearhead: GFS4G□

Mass: 1.9 kg

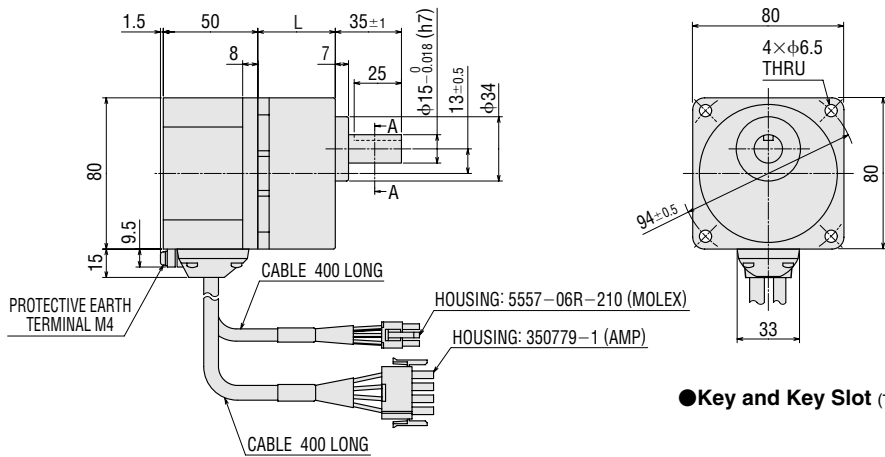

● Key and Key Slot (The key is included with the gearhead.)

- GFS4G5~20: L=41
- GFS4G30~100: L=46
- GFS4G200: L=51

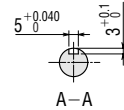
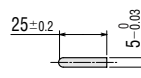

◇ Motor/Hollow Shaft Flat Gearhead

BLF460C-□FR (Combination type -Hollow shaft flat gearhead)

Motor: BLFM460-GFS

Gearhead: GFS4G□FR

Mass: 2.5 kg

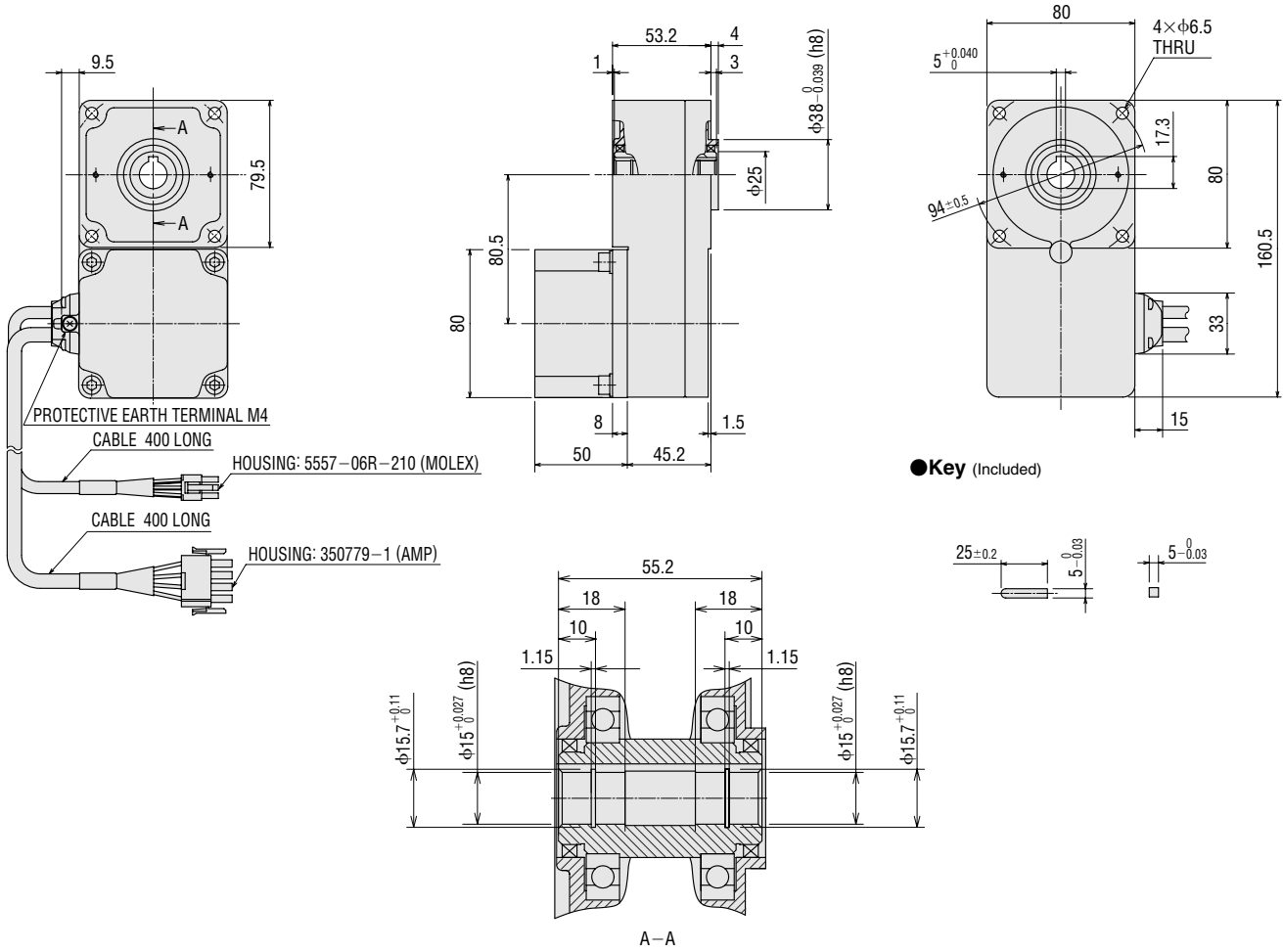

◇ Round Shaft Type

BLF460C-A (Round shaft type)

Motor: BLFM460-A

Mass: 0.9 kg

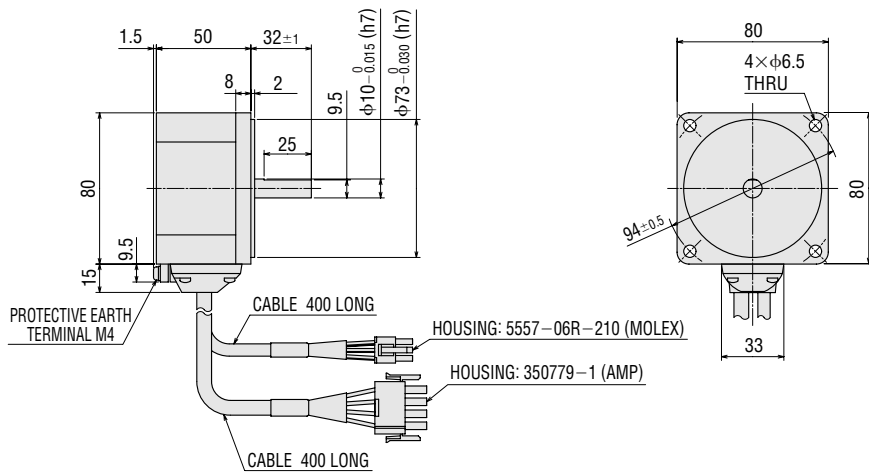

◇ Motor/Parallel Shaft Gearhead

BLF5 120C-□ (Combination type -Parallel shaft gearhead)

Motor: BLFM5120-GFS

Gearhead: GFS5G□

Mass: 3.0 kg

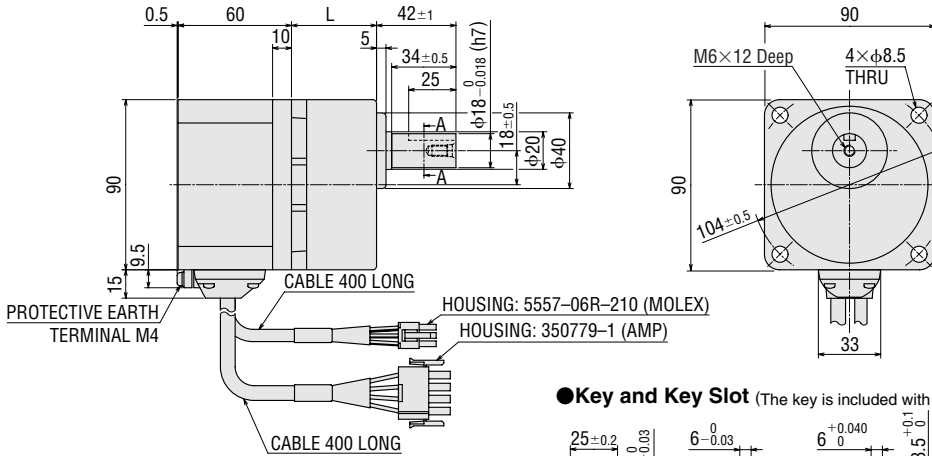

● Key and Key Slot (The key is included with the gearhead.)

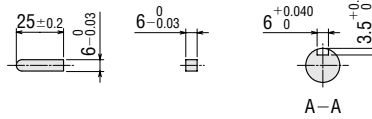

GFS5G5~20: L=45
 GFS5G30~100: L=58
 GFS5G200: L=64

◇ Motor/Hollow Shaft Flat Gearhead

BLF5 120C-□FR (Combination type -Hollow shaft flat gearhead)

Motor: BLFM5120-GFS

Gearhead: GFS5G□FR

Mass: 3.7 kg

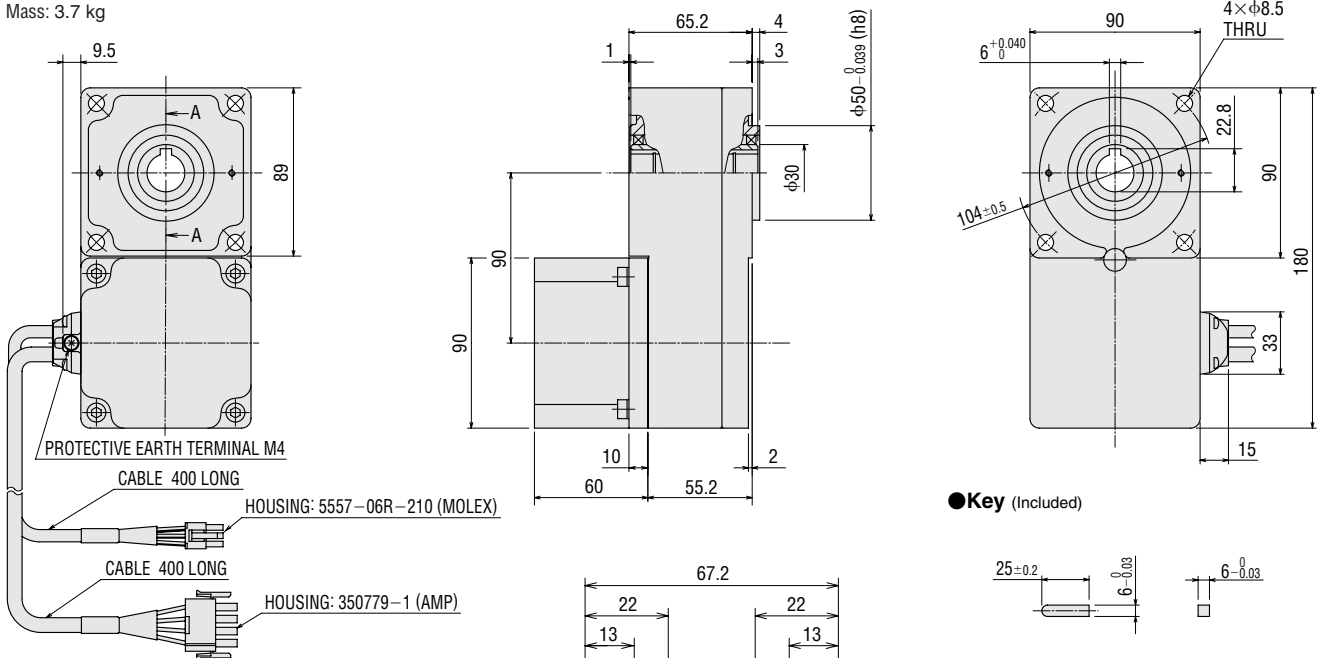

● Key (Included)

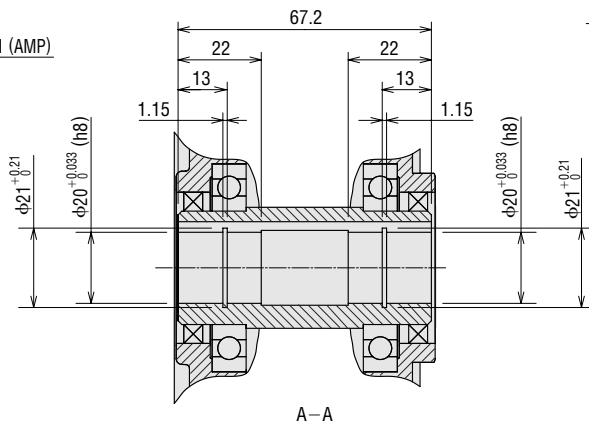
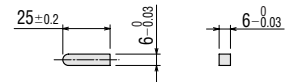

◇ Round Shaft Type

BLF5120C-A (Round shaft type)

Motor: BLFM5120-A

Mass: 1.5 kg

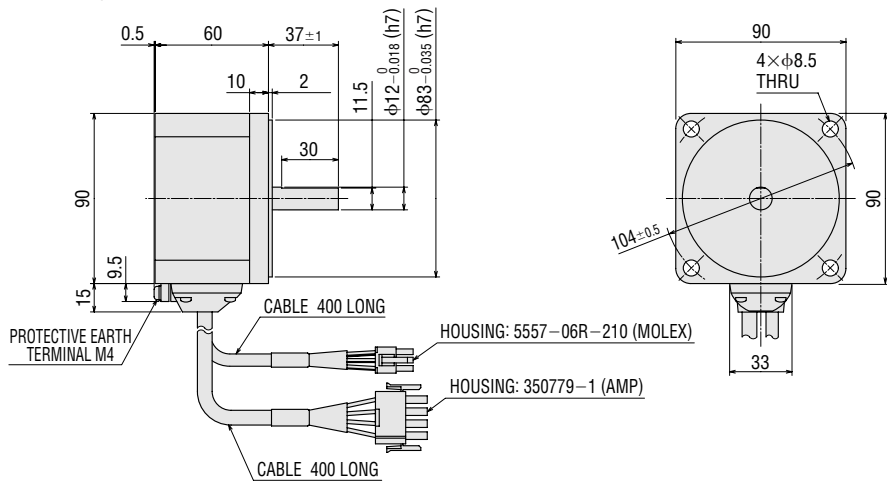

◇ Driver

BLFD30C2

BLFD60C2

BLFD120C2

Mass: 0.9 kg

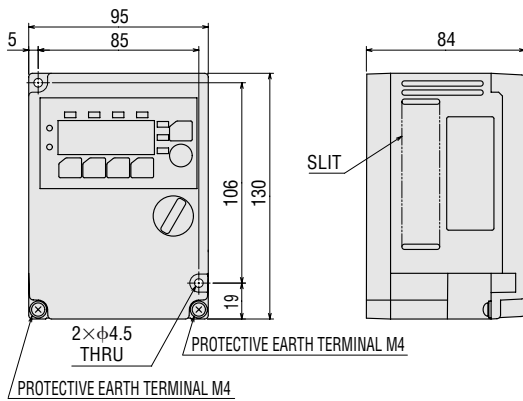

◇ Digital Operator

(Detached from the driver)

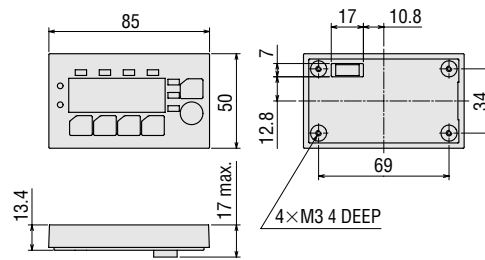

◇ Digital Operator Panel Cut-Out

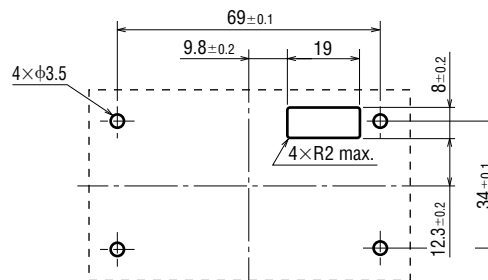

Connection and Operation

Name and Function of each Part of the Driver

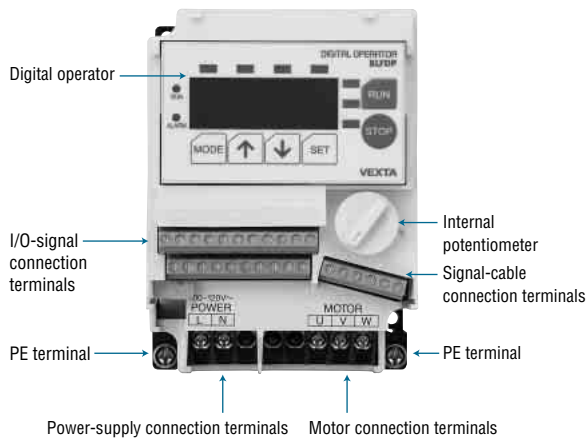

Digital Operator

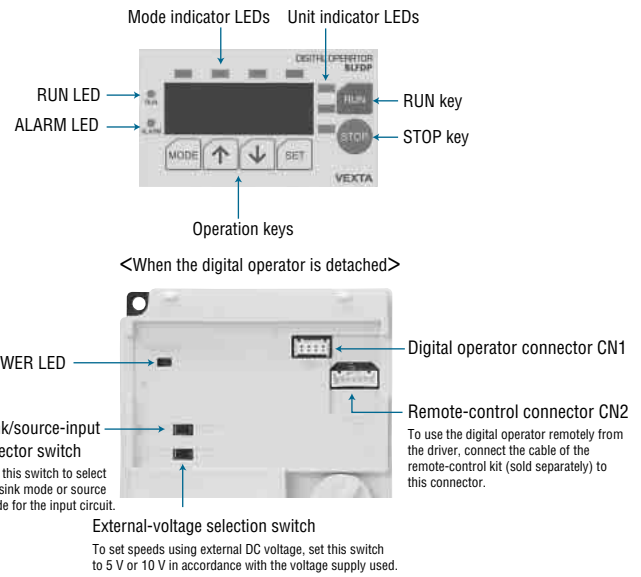

I/O Signals

Terminal Name	Signal	Signal Name	Function and Operation
TH		-	Do not connect any signal to this terminal.
TH		-	Do not connect any signal to this terminal.
M0	Input	M0 Input	These signals are used to select operation data in multi-speed operation. One of up to eight preset speed data can be selected using the M0, M1 and M2 inputs.
M1		M1 Input	
M2		M2 Input	
VH		VH Input	These signals are used to set speeds via an external potentiometer or external DC Voltage.
VM		VM Input	
VL		VL Input	
C3		IN-COM1	
X0*1		EXT-ERROR Input	Input signal common (0 V)
C0	IN-COM0	Input signal common	
C1	IN-COM0	Input signal common	
X1*2	2-wire Mode: CW Input	Clockwise direction/stop switch input signal	
	3-wire Mode: START/STOP Input	Start/stop input signal	
X2*2	2-wire Mode: CCW Input	Counterclockwise direction/stop switch input signal	
	3-wire Mode: RUN/BRAKE Input	Run/instantaneous stop input signal	
X3*2	2-wire Mode: STOP-MODE Input	This signal is input to select the motor stop action.	
	3-wire Mode: CW/CCW Input	Clockwise/counterclockwise direction input signal	
X4		-	Do not connect any signal to this terminal.
X5		ALARM-RESET Input	This signal is used to reset alarms.
Y1	Output	ALARM-OUT1 Output	This signal is output upon generation of an alarm. (Normally closed)
Y2		ALARM-OUT2 Output	This signal is output upon actuation of the overload protection function or overload warning function. (Normally closed)
Y0		SPEED-OUT Output	30 pulses are output per each revolution of the motor output shaft.
C2		OUT-COM	Output signal common.

*1 Do not remove the short bar if the EXT-ERROR input is not used.

*2 The functions of the external-input signal terminals X1, X2 and X3 can be changed between the 2-wire input mode and 3-wire input mode. The functions under the 2-wire input mode are initially assigned to the terminals.

Digital Operator Indicators

Display	Function	Details
RUN	Running	A green lamp stays lit while the motor is running.
ALARM	Alarm	A red lamp turns on when an alarm occurs.
Mode	MNTR	Monitor mode The motor can be operated in this mode. The motor speed and load condition are displayed during motor operation.
	F/R	Direction setting mode If the digital operator is used to operate the motor, set the motor direction in this mode. For: Clockwise direction, rEv: Counterclockwise direction
	LO/RE	Digital operator/external-input signal setting mode In this mode, set whether to use the digital operator or external I/O signals to input the motor operation/stop signals. Lo: Digital operator, rE: External input signals
Display Unit	PRGM	Data setting mode In this mode, set the data needed to operate the motor. Operation data (eight speeds and acceleration/deceleration times) Gear ratio setting/conveyor speed setting Input mode Overload warning function
	r/min	Motor speed The speed of the motor or gearhead output shaft is displayed.
	m/min	Conveyor speed An equivalent moving speed of the work on a conveyor or other transfer system is displayed.
%	Load factor*	The actual load is displayed as a percentage of the rated torque being 100%.

* A maximum error of approx. 20% may generate when the motor is operated at the rated speed under the rated load.

Connection Diagrams

The figure below is a connection diagram for a configuration based on a single-phase 200–240 V supply voltage, with the sink/source selector switch set to the source side.

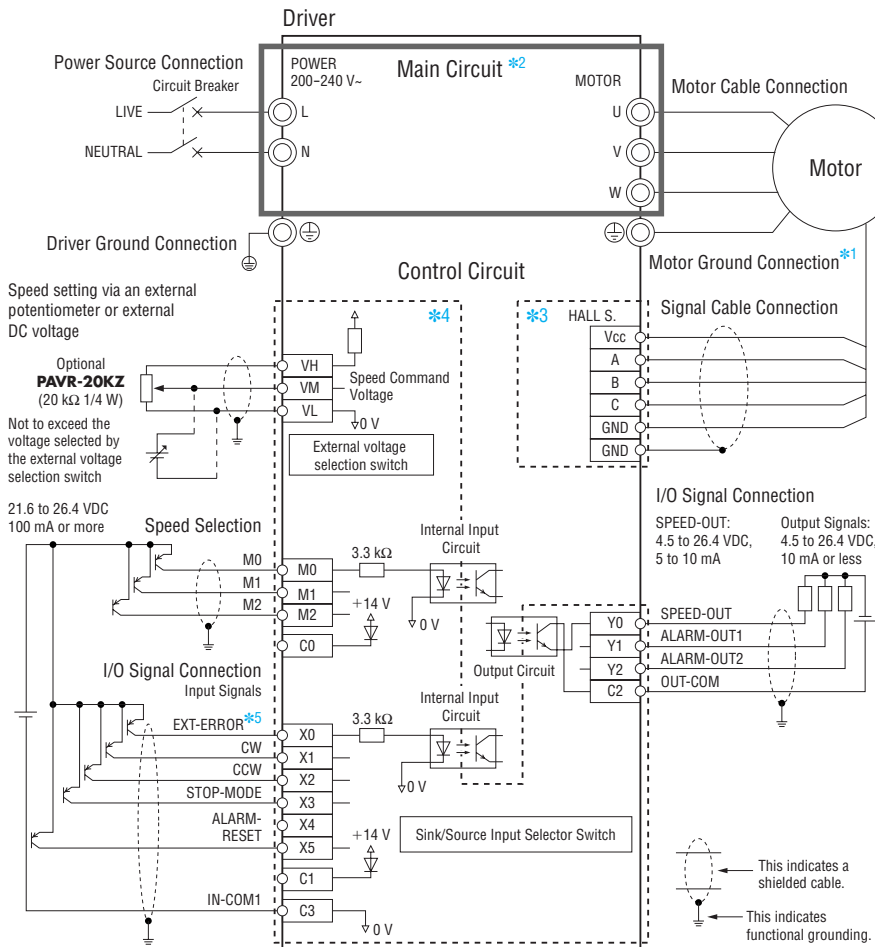

- *1 The grounding method will vary depending on the length of the connection cable.
When the connection cable is 7 m or shorter: Connect the protective grounding terminal on the connection cable to the protective grounding terminal on the driver.
When the connection cable is 10 m or longer: Connect the protective grounding terminal of the motor directly to the grounding point.
- *2 The main circuit is insulated to prevent electrical shock resulting from accidental contact by a hand, etc.
- *3 The signal-cable connection terminals and the signal cable including the shielded cable comprise an ELV circuit, which is insulated from dangerous voltages only by means of basic insulation. Therefore, connect the shielded cable to the GND point specified in the connection diagram, instead of connecting it to a protective grounding terminal.
- *4 The I/O-signal connection terminals comprise a SELV circuit, which is insulated from dangerous voltages by means of double insulation or reinforced insulation.
- *5 X0 is an external error input. When this signal turns OFF, an alarm will be output.

Applicable Crimp Terminals

- Power Supply Connection Terminal (M3.5): Round shape terminal with insulator

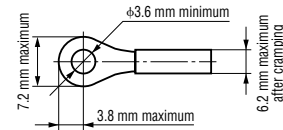

- Protective Earth Terminal (M4): Round shape terminal with insulator



I/O Terminals

Use the terminals specified below for connection using crimp terminals. Please note that the applicable crimp terminal will vary depending on the size of the wire. The following terminals can be used with wires of AWG26 to 22. [Manufacturer: Phoenix Contact]
AI 0.25-6 Applicable cable size : AWG26~24 (0.14~0.2 mm²)
AI 0.34-6 Applicable cable size : AWG22 (0.35 mm²)

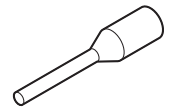

Timing Chart

2-wire Mode

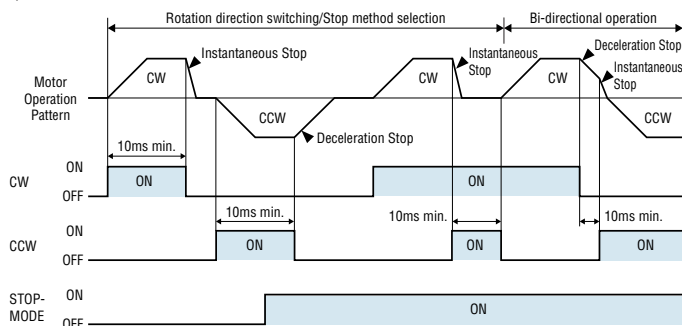

- The CW input signal, CCW input signal and DEC-STOP signal can be used to control all motor operations, such as run, stop, direction switching, deceleration stop and instantaneous stop.
- Switching the CW signal ON will cause the motor to turn clockwise as viewed from the motor shaft, while switching the CCW signal ON will cause the motor to turn counterclockwise. Switching each signal OFF will stop the motor. If both the CW signal and CCW signal are turned ON at the same time, the motor will stop instantaneously. The motor will start at the rise time corresponding to the acceleration time (ACC) set on the digital operator.
- Switching the STOP-MODE signal ON will cause the motor to decelerate at the deceleration time (DEC) set on the digital operator until it eventually stops. Switching the STOP-MODE signal OFF will cause the motor to stop instantaneously.

3-wire Method

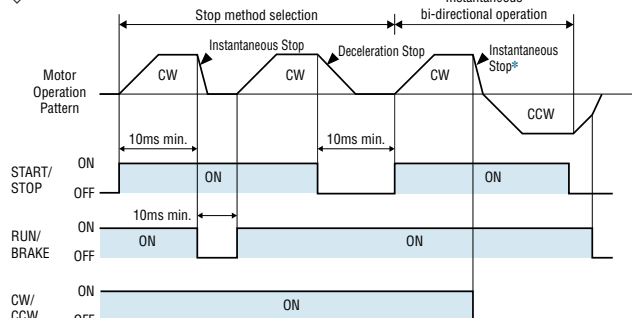

- The START/STOP signal, RUN/BRAKE signal and CW/CCW signal can be used to control all motor operations, such as run/stop, instantaneous stop and direction switching.
- Switching both the START/STOP signal and RUN/BRAKE signal ON at the same time will start the motor. At this time, switching the CW/CCW signal ON will cause the motor to turn clockwise as viewed from the motor shaft, while switching the signal OFF will cause the motor to turn counterclockwise. The motor will start at the rise time corresponding to the acceleration time (ACC) set on the digital operator.
- Switching the RUN/BRAKE signal OFF while the START/STOP signal is ON will cause the motor to stop instantaneously. Switching the START/STOP signal OFF while the RUN/BRAKE signal is ON will cause the motor to decelerate at the deceleration time (DEC) set on the digital operator until it eventually stops.

* Changing the direction while the motor is running will cause the motor to stop instantaneously and then change its direction.

I/O Signal Circuits

The input signal circuit can be switched between the sink mode and source mode using the sink/source selector switch on the driver.

Input Circuit

Common to the CW (START/STOP), CCW (RUN/BRAKE), STOP-MODE (CW/CCW), EXT-ERROR, ALARM-RESET and operation-data selection inputs.

Source Logic

- Controlled by Relays or Switches

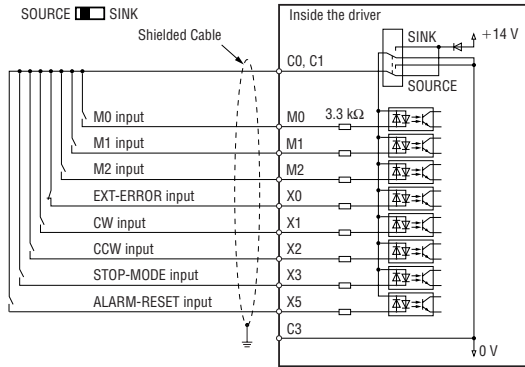

Sink Logic

- Controlled by Relays or Switches

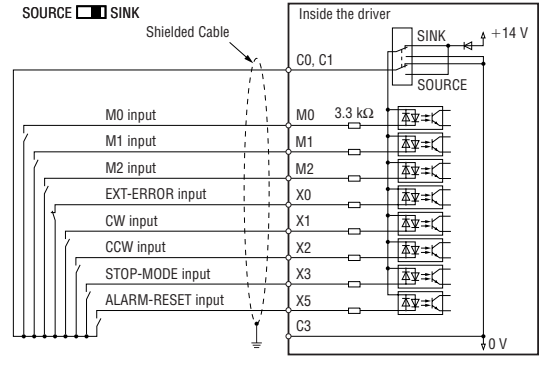

- Controlled by Transistor

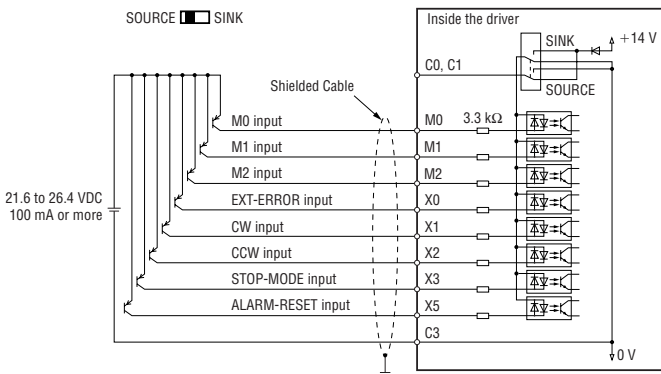

- Controlled by Transistor

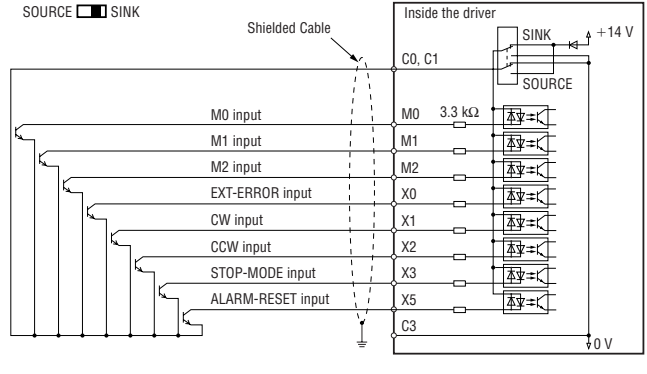

Output Circuit

Common to the SPEED-OUT, ALARM-OUT1 and ALARM-OUT2 outputs.

Source Logic

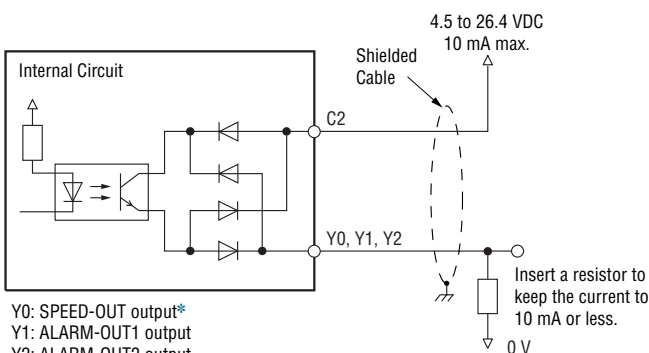

Y0: SPEED-OUT output*
Y1: ALARM-OUT1 output
Y2: ALARM-OUT2 output

* Supply a current of 5 mA or more to the SPEED-OUT output.

Sink Logic

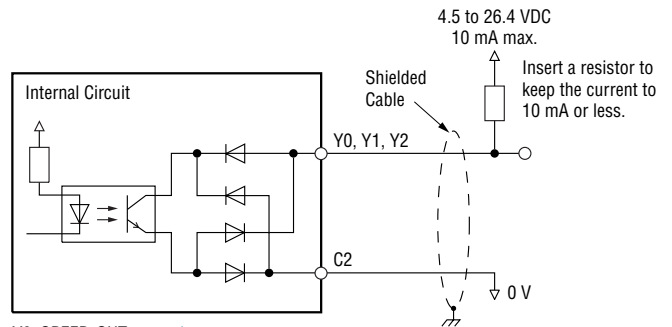

Y0: SPEED-OUT output*
Y1: ALARM-OUT1 output
Y2: ALARM-OUT2 output

* Supply a current of 5 mA or more to the SPEED-OUT output.

◆When a Controller with a Built-in Clamp Diode is Used

When you want to use the controller with a built-in clamp diode, pay attention to the sequence of turning on or off the power.

Power ON: Controller ON → Driver ON
Power OFF: Driver OFF → Controller OFF

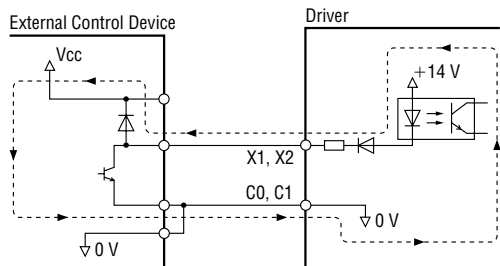

If the driver power is turned on first when connected as shown above, or the controller power is turned off with the driver power turned on, current will be applied, as indicated by the arrows in the diagram. This may cause the motor to run.

When the power is turned on or off simultaneously, the motor may run temporarily due to differences in power capacity. The controller power must be turned on first, and driver power must be turned off first.

◆SPEED-OUT Output

Pulse signals of 30 pulses (pulse width: 0.2 ms) are output per each revolution of the motor output shaft in synchronization with the motor operation.

By measuring the frequency of SPEED outputs, the motor speed can be calculated.

$$\text{SPEED-OUT Output Frequency (Hz)} = \frac{1}{T}$$

$$\text{Motor Shaft Speed (r/min)} = \frac{\text{SPEED-OUT Output Frequency}}{30} \times 60$$

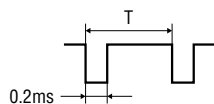

◆ALARM-OUT1 Output

When any of the driver's protection functions is actuated, the ALARM-OUT1 output will turn OFF and the digital operator will display an alarm code. The motor will decelerate to a stop.

◆ALARM-OUT2 Output

The ALARM-OUT2 output will turn OFF when the driver's overload protection function or overload warning function is actuated. Actuation of any other protection function will not turn this output OFF. The overload warning function is actuated based on a preset load factor relative to the rated torque. The ALARM-OUT2 output will turn OFF once the set load factor is exceeded.

(A desired load factor can be set at 10% intervals between 50 and 100%.)

Type of Protection Function	ALARM-OUT1 Output	ALARM-OUT2 Output
Normal Operation	ON	ON
Overload Protection Function	OFF	OFF
Other Protection Function	OFF	ON
Overload Warning Function*	ON	OFF

* A maximum error of approx. 20% may generate when the motor is operated at the rated speed under the rated load.

●Operating Methods

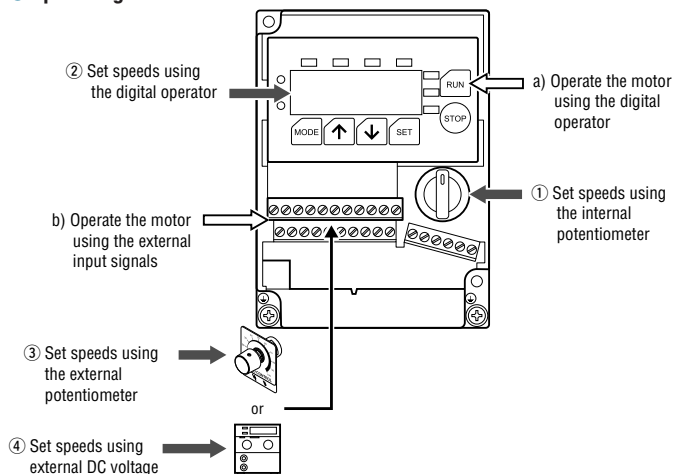

One of the following two operating methods (a and b) can be set by switching between the digital-operator setting mode and external-input signal setting mode.

- a) Operate the motor using the RUN and STOP keys on the digital operator
- b) Operate the motor using external input signals

●Speed Setting Methods

One of the following four methods (① to ④) can be used to set speeds:

① Set speeds using the internal potentiometer

Set speeds using the potentiometer provided on the driver's front panel.

② Set speeds using the digital operator

The digital operator can be used to set speeds in units of 1 r/min. Up to eight speed data can be set.

③ Set speeds using an external potentiometer (sold separately)

To set speeds at a location away from the driver, connect an optional external potentiometer as shown below.

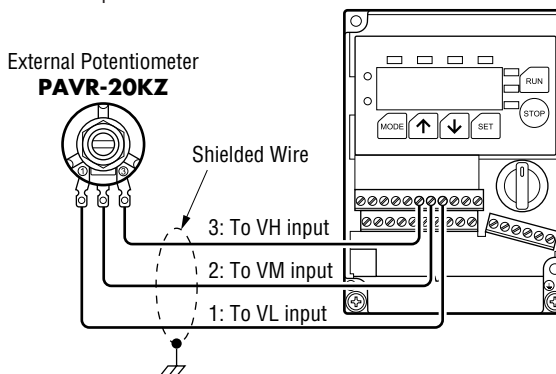

External Potentiometer Graduation vs. Speed Characteristics (Representative values)

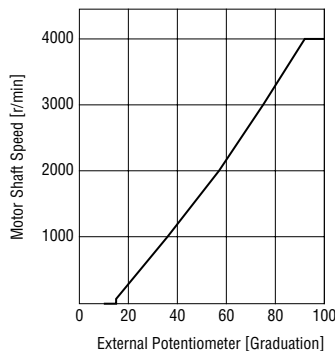

Note:

The speed in the graph represents the speed of a motor alone. The gear output shaft speed of the combination type is calculated by dividing the graph speed by the gear ratio.

④ Set speeds using external DC voltage

Set the external-voltage selection switch on the driver in accordance with the external DC voltage to be supplied. Detach the digital operator and set the switch to either 5 V or 10 V. Thereafter, connect an external DC power supply as shown below. Connect the positive and negative terminals of the power supply correctly.

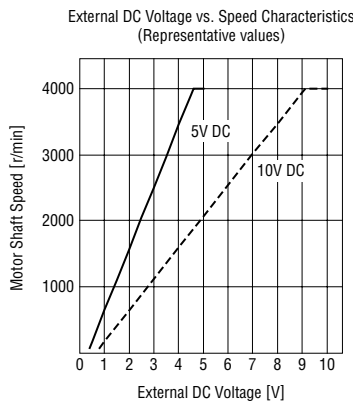
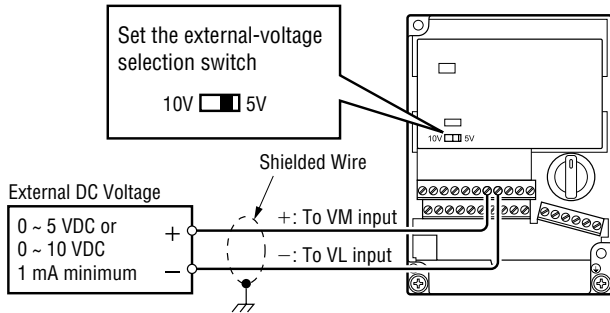

Note:

The speed in the graph represents the speed of a motor alone. The gear output shaft speed of the combination type is calculated by dividing the graph speed by the gear ratio.

● Multi-Speed Operation

◇ Two-Speed Operation

The speed set by the internal potentiometer and another set by an external potentiometer can be combined for two-speed operation by switching the operation-data selection input M0.

M0 Input	M1 Input	M2 Input	Speed Setting Method
OFF	OFF	OFF	Internal potentiometer
ON	OFF	OFF	External potentiometer

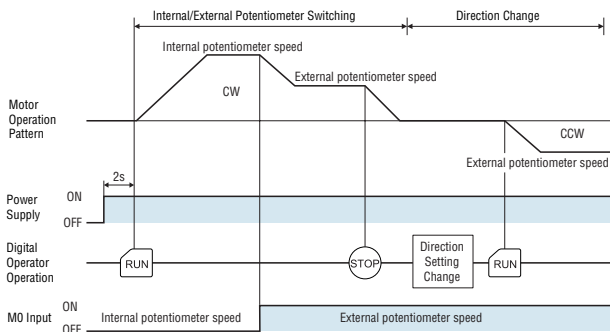

◇ Eight-Speed Operation

A multi-speed operation using up to eight speeds can be performed by setting desired speeds in operation data No. 1 to 8 and then switching the speed using external input signals.

Operation Data	M0 Input	M1 Input	M2 Input	Speed Setting Method
No. 1	OFF	OFF	OFF	Internal potentiometer/Digital operator
No. 2	ON	OFF	OFF	External potentiometer/Digital operator
No. 3	OFF	ON	OFF	Digital operator
No. 4	ON	ON	OFF	Digital operator
No. 5	OFF	OFF	ON	Digital operator
No. 6	ON	OFF	ON	Digital operator
No. 7	OFF	ON	ON	Digital operator
No. 8	ON	ON	ON	Digital operator

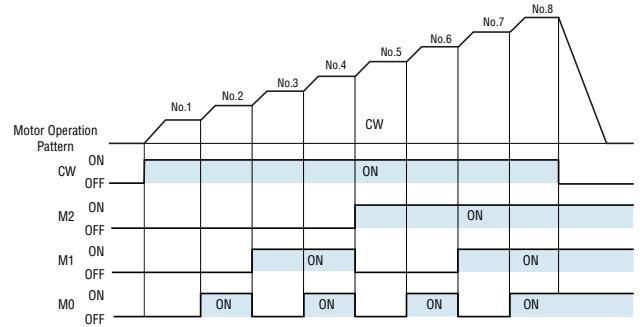

● Parallel Operation

Two or more motors can be operated at the same speed using a single external potentiometer or external DC power supply. The diagram below applies to a single-phase power supply specification. Also note that the diagram does not show the motor or operation control part.

◇ Using an External Potentiometer

As shown in the diagram, use a common power-supply line and a common speed-control line for each driver and set speeds using the external potentiometer VRx.

The resistance of the external potentiometer is determined using the formula below:

Resistance when n numbers of drivers are connected: $VR_x = 20 / n$ (kΩ), $n / 4$ (W)

Example: When two drivers are connected

$$VR_x = 20 / 2 = 10 \text{ (k}\Omega\text{)}, 2 / 4 = 1 / 2 \text{ (W)}$$

Accordingly, the resistance is calculated as 10 kΩ, 1/2 W.

To adjust the speed difference between motors, connect a 1.5 kΩ, 1/4 W resistor to the VM terminal on the first driver, and connect a 5 kΩ, 1/4 W variable resistor (VRn) to the VM terminal on each of the remaining drivers.

Up to five drivers can be operated in parallel using an external potentiometer.

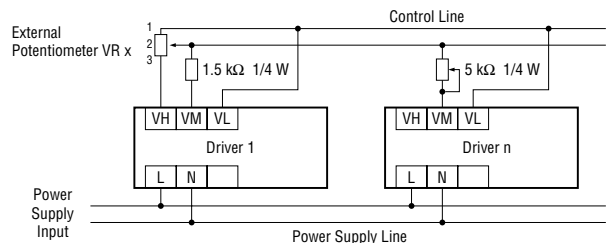

◇Using External DC Voltage

As shown in the diagram, use a common power-supply line and a common speed-control line for each driver and connect all drivers to a 5 or 10 VDC power supply.

The power-supply capacity of the external power supply is determined using the formula below:

Power-supply capacity when n numbers of drivers are connected: $I=1 \times n$ (mA)

Example: When two drivers are connected

$$I=1 \times 2=2 \text{ (mA)}$$

Accordingly, the power-supply capacity is calculated as 2 mA or more.

To adjust the speed difference between motors, connect a 1.5 kΩ, 1/4 W resistor to the VM terminal on the first driver, and connect a 5 kΩ, 1/4 W variable resistor (VRn) to the VM terminal on each of the remaining drivers.

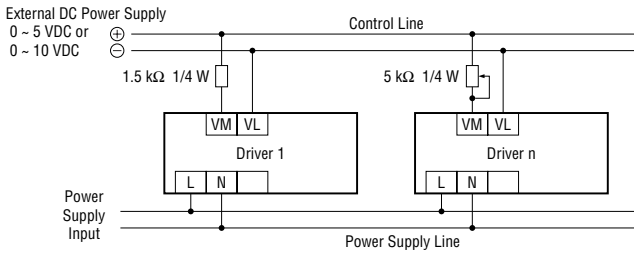

◇Using the Digital Operator

When multiple drivers are connected where the same data are set digitally in each driver, the operations of multiple motors can be controlled via a single set of external input signals using the wiring circuit shown below.

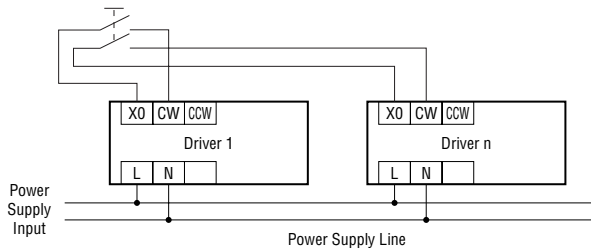

Installation of the Hollow-Shaft Flat Gearhead

● Installing the Load Shaft

- Install the load shaft to the hollow output shaft by aligning the center of the hollow shaft with that of the load shaft.
- The hollow output shaft has a key groove. Machine a matching key groove on the load shaft side and use the supplied key to affix the two shafts across the grooves.
- A recommended tolerance of the load shaft is h7.
- If the motor will receive large impacts due to frequent instantaneous stops or carry a large overhung load, use a stepped load shaft.

Notes:

- When installing the load shaft to the hollow output shaft, be careful not to damage the hollow output shaft or bearing.
- To prevent seizure, apply a coat of molybdenum disulfide grease on the exterior surface of the load shaft and interior surface of the hollow output shaft.
- Do not attempt to modify or machine the hollow output shaft. Doing so may damage the bearing and cause the hollow-shaft flat gearhead to break.

◇ Stepped Load Shaft

Install a hexagonal socket head bolt over a stopper ring, spacer, flat washer and spring washer, and tighten the bolt to affix the load shaft.

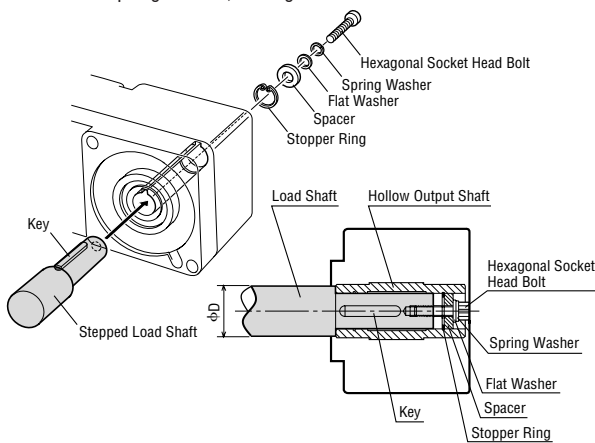

◇ Straight Load Shaft

Install a hexagonal socket head bolt over a stopper ring, spacer, flat washer and spring washer, with a spacer also inserted underneath the load shaft, and tighten the bolt to affix the load shaft.

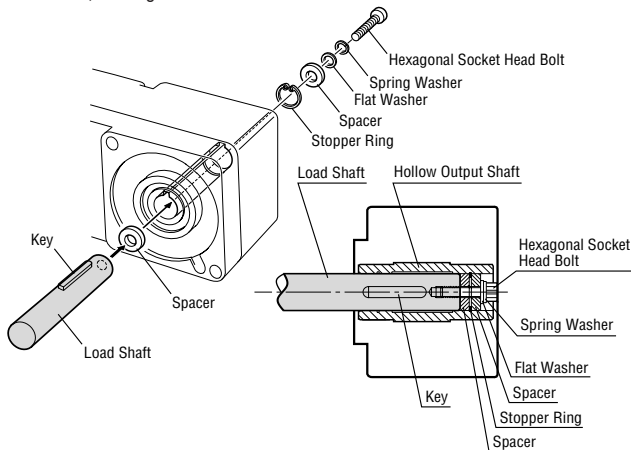

● Recommended Load Shaft Installation Dimensions

Unit=mm

Model	BLF230	BLF460	BLF5120
Inner Diameter of Hollow Shaft (h8)	φ12 $+0.027_0$	φ15 $+0.027_0$	φ20 $+0.033_0$
Recommended Tolerance of Load Shaft (h7)	φ12 $_0^{-0.018}$	φ15 $_0^{-0.018}$	φ20 $_0^{-0.021}$
Nominal Diameter of Stopper Ring	φ12, C-shaped	φ15, C-shaped	φ20, C-shaped
Applicable Bolt	M4	M5	M6
Spacer Thickness*	3	4	5
Outer Diameter of step part φD	20	25	30

* Determine the spacer thickness in conformance with the table. If the spacer is thicker than the specified dimension, the bolt will project from the surface and interfere with the safety cover.

● Installing the Hollow Shaft

◇ Installing from the Front Face

The output shaft boss (h8) can be used to align the shaft.

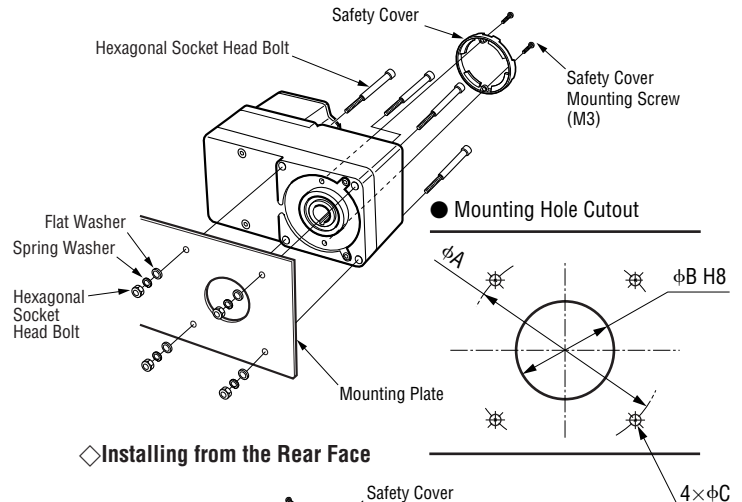

◇ Installing from the Rear Face

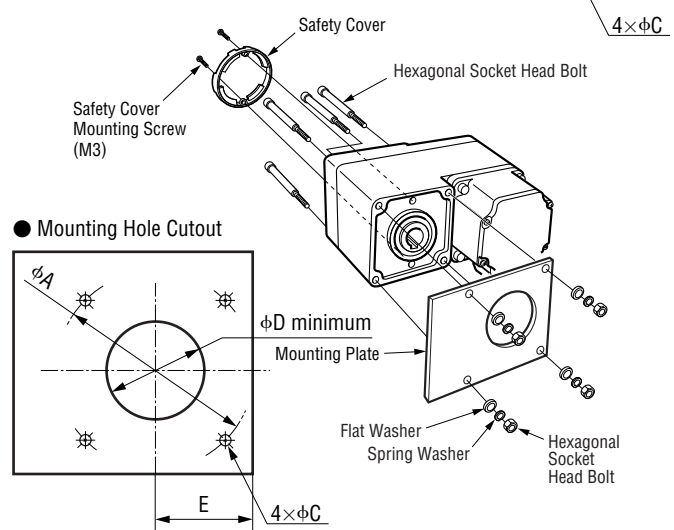

Note:

When installing the hollow-shaft flat gearhead from the rear face, provide dimension E to prevent the mounting plate from contacting the motor.

● Mounting Hole Dimensions

Unit=mm

Model	BLF230	BLF460	BLF5120
Nominal Bolt Size	M5	M6	M8
φA	70	94	104
φB H8	34 $+0.039_0$	38 $+0.039_0$	50 $+0.039_0$
φC	5.5	6.5	8.5
φD	25	30	35
E	29	39	44

■ Connection Cables (RoHS) (Sold Separately)

These cables are used to connect the motor and driver. The **BLF** Series does not come with connection cables, so be sure to purchase an optional connection cable set. The optional cable set consists of two cables including a motor connection cable and a signal connection cable.

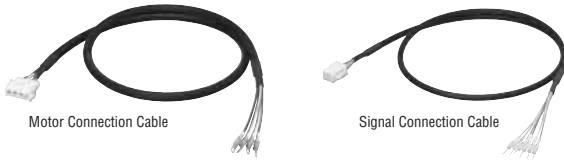

● Cable Set

Model	Length (L)
CC01BLF	1 m
CC02BLF	2 m
CC03BLF	3 m
CC05BLF	5 m
CC07BLF	7 m
CC10BLF	10 m
CC15BLF	15 m
CC20BLF	20 m

● Dimensions unit: mm

◇ Motor Connection Cable 1~7 m

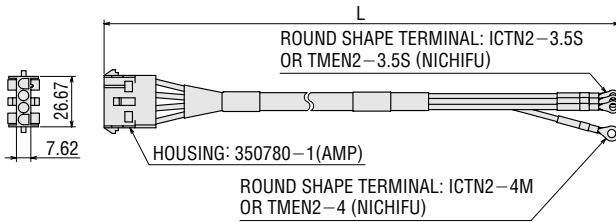

◇ Motor Connection Cable 10~20 m

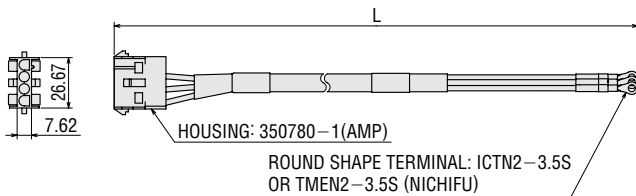

◇ Signal Connection Cable

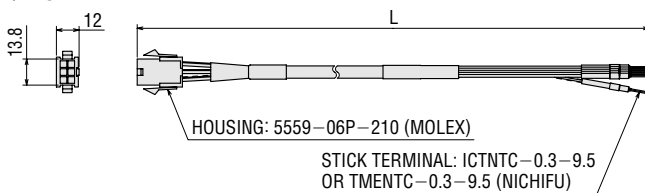

Accessories (Sold Separately)

■ Remote-Control Kit (RoHS)

The remote-control kit is useful if you want to detach the digital operator from the driver and install it on the frame of the equipment, etc., for remote operation.

The kit includes an extension cable for digital operator/driver connection [2 or 5 m] and a rubber gasket.

Model	Extension Cable Length
BLFHS-02	2 m
BLFHS-05	5 m



<Example of use>



■ External Potentiometer (RoHS)

Model: **PAVR-20KZ**

(20kΩ, 1/4W, with a linear resistance vs. angle curve)



Mounting Bracket RoHS

These mounting brackets are useful for installing or fixing the parallel shaft combination type and round shaft type.

To mount the round shaft type, mounting screws must be provided separately. Please note that these mounting brackets cannot be used with hollow shaft flat gearheads.



Model	Applicable Products
SOL2M4	BLF230C-□ BLF230C-A
SOL4M6	BLF460C-□ BLF460C-A
SOL5M8	BLF5120C-□ BLF5120C-A

- Enter the gear ratio in the box (□) within the applicable motor model name.
- The mounting brackets come with tapped holes. To mount the motor and gearhead, simply fasten with the screws provided to the gearhead.

Dimensions unit: mm

Model: SOL2M4

Mass: 135 g Material: Aluminum

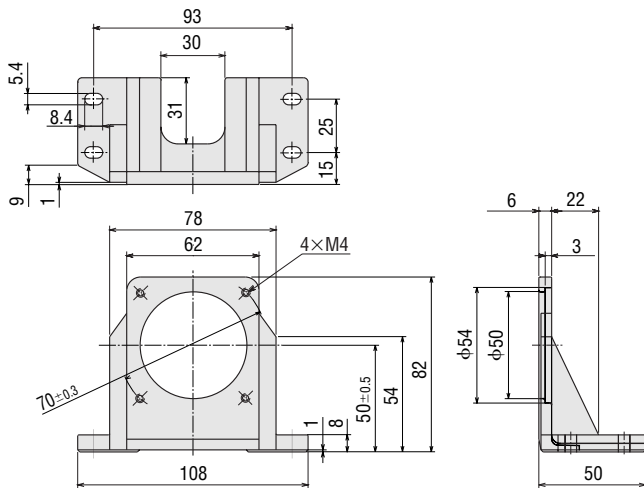

Model: SOL5M8

Mass: 270 g Material: Aluminum

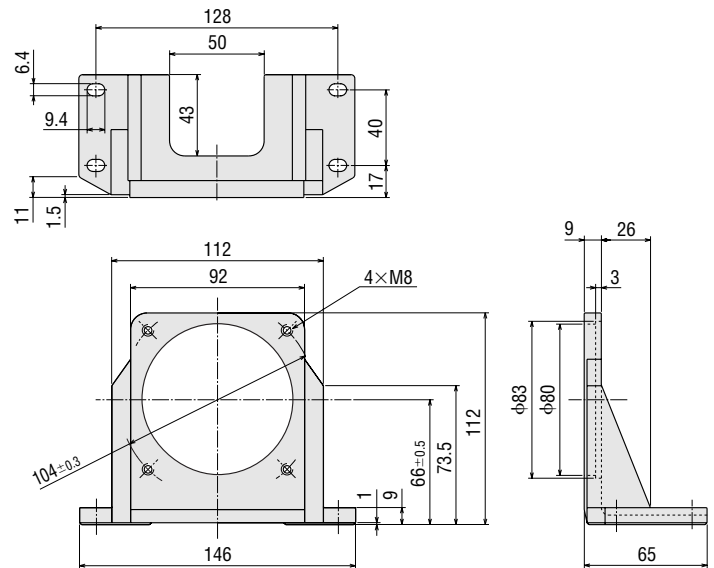

Model: SOL4M6

Mass: 210 g Material: Aluminum

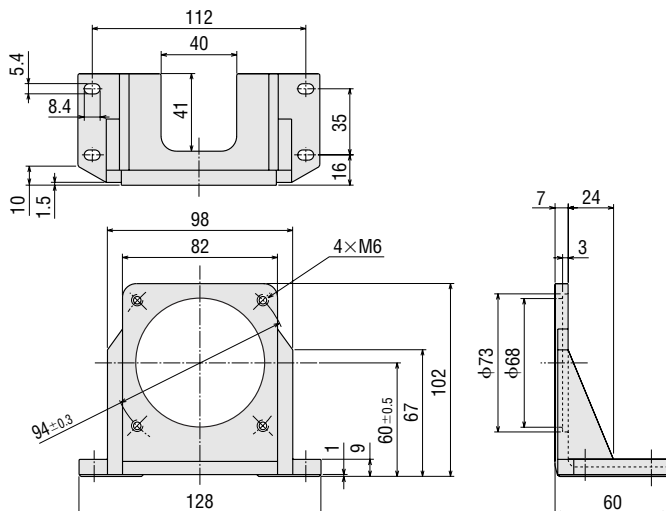

This product is manufactured at a plant certified with the international standards **ISO 9001** (for quality assurance) and **ISO 14001** (for systems of environmental management).

Specifications are subject to change without notice.
This catalogue was published in November, 2006.

Orientalmotor

ORIENTAL MOTOR (EUROPA) GmbH

www.orientalmotor.de

European Headquarters and Düsseldorf Office

Schießstrasse 74
40549 Düsseldorf, Germany
Tel: 0211-5206700 Fax: 0211-52067099

Munich Office

Liebigstrasse 14
85757 Karlsfeld, Germany
Tel: 08131-59880 Fax: 08131-598888

Hamburg Office

Meckelfelder Weg 2
21079 Hamburg, Germany
Tel: 040-76910443 Fax: 040-76910445

Stuttgart Office

Tel: 07335-924853 Fax: 07335-924854

ORIENTAL MOTOR (UK) LTD.

www.oriental-motor.co.uk

Unit 5, Faraday Office Park,
Rankine Road, Basingstoke,
Hampshire RG24 8AH U.K.
Tel: 01256-347090 Fax: 01256-347099

ORIENTAL MOTOR (FRANCE) SARL

www.orientalmotor.fr

France Headquarters

32, Avenue de l'île Saint Martin
92737 Nanterre Cedex, France
Tel: 01 47 86 97 50 Fax: 01 47 82 45 16

Lyon Office

10, Allée des Sorbiers
69673 Bron Cedex, France
Tel: 04 78 41 15 02 Fax: 04 78 41 15 90

ORIENTAL MOTOR ITALIA s.r.l.

www.orientalmotor.it

Italy Headquarters

Via A. De Gasperi, 85
20017 Mazzo di Rho (MI), Italy
Tel: 02-93906346 Fax: 02-93906348

Bologna Office

Via Mori, 6
40054 Prunaro di budrio (BO), Italy
Tel: 051-6931249 Fax: 051-6929266

ORIENTAL MOTOR CO., LTD.

www.orientalmotor.co.jp

Headquarters

16-17, Ueno 6-chome
Taito-ku, Tokyo 110-8536, Japan
Tel: (03)3835-0684 Fax: (03)3835-1890

For more information please contact:



This printed material uses recycled paper and soy inks. This combination is environmentally friendly.

Printed in Japan 06Y 2K 32800K