

RoHS Compliant Rack and Pinion Systems LS Linear Heads

Additional Information
Technical reference → Page F-1

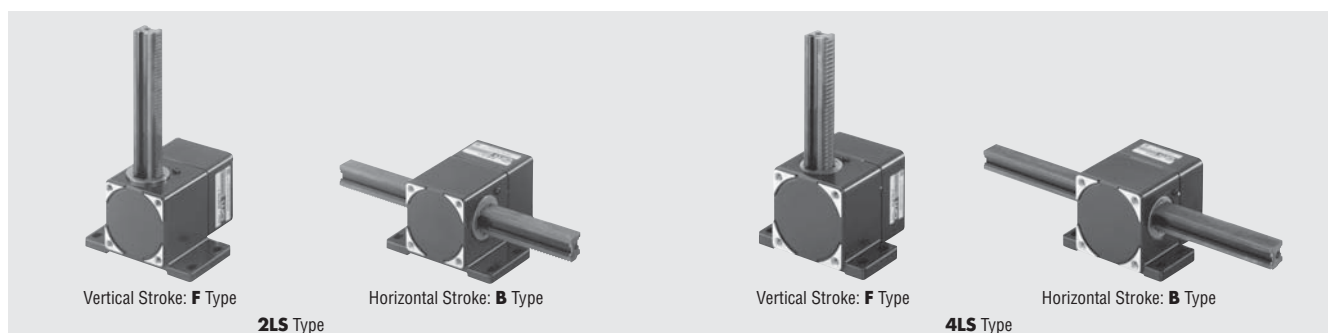

Features

Easy to Achieve Linear Motion Mechanism

If a simple operation is repeated, a suitable linear motion mechanism can be realized with ease regardless of whether the rack moves in the horizontal or vertical direction.

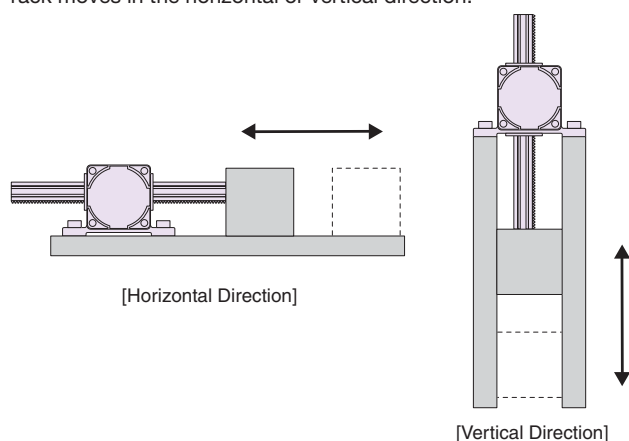

High Thrust Force and Large Transportable Mass

The maximum transportable mass is approximately 1.5 times that of a conventional product. (The specific value varies depending on the basic speed of rack.)

- 100 kg (4LS type)
- 30 kg (2LS type)

Effective Utilization of Space

With a linear head, both ends of the rack can be affixed to the head to travel, as shown below. This structure facilitates space-saving design.

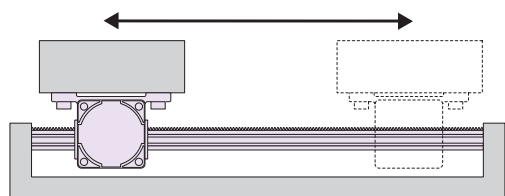

Many Stroke Variations

Select the stroke that best suits your specific application.

- 100~1000 mm: 10 types (4LS type)
- 100~800 mm: 8 types (2LS type)

RoHS Compliant

The LS linear heads conform to the RoHS Directive that prohibits the use of six chemical substances including lead and cadmium.

- Details of RoHS Directive → Page G-23

Limit Switches Make Reciprocating Motion Easy

Use dedicated limit switches (sold separately) to implement reciprocating motion or intermediate stops with ease.

- Limit switch set → Page D-125

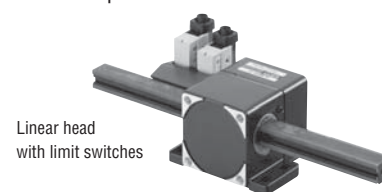

Special Dog Shape

The special dog shape allows signals to be output separately at two moving ends, or at a moving end and an intermediate stop position. Accordingly, control can be implemented easily using the minimum number of limit switches.

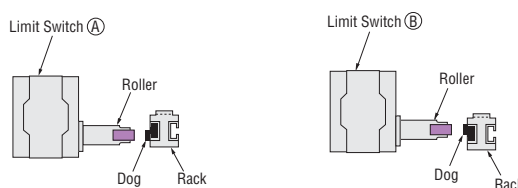

Installation of Dog

The installation direction in the rack groove can be changed to effectively support two limit switches.

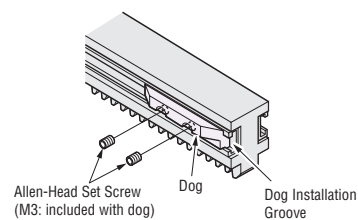

Easy Position Setting Using Dedicated Limit Switches and Dogs

Since the roller of the limit switch can travel over the dog, multiple-point stop operation can be designed easily by increasing the number of dogs.

The figure below shows an example where the actuator performs reciprocating motion while stopping at two intermediate points. Dog (a) defines the home, while dog (b) is used for reversing and dogs (c) and (d) cause the actuator to stop at intermediate points. To make control simple, use limit switch (b) as signal for home and limit switch (a) as signal for intermediate stop or reversing.

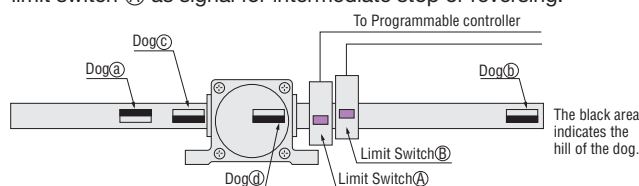

- The dog is 35 mm long. The number of dogs that can be installed is limited.
- Relays and a programmable controller will be needed to control the motor using signals detected from these limit switches.

System Configuration

An example of system configuration with **LS** linear head and a standard AC motor World **K** Series.

LS Linear Head (Body)

Accessories (Sold separately)

No.	Product Name	Overview	Page
①	Limit Switch Set	Used for reciprocating motion, these limit switches can be installed easily to a LS linear head (PARP-MS).	D-125
②	Dog	This dog is needed to operate a limit switch during reciprocating motion (LXDT-4).	D-125
③	CR Circuit for Surge Suppression	Used to protect relay and switch contacts (EPCR1201-2).	D-125

● Example of System Configuration



● The system configuration shown above is an example. Other combinations are available.

Product Number Code

2 LS F 10 - 2

① ② ③ ④ ⑤

①		2: Can be combined with GN pinion motors of frame size 60 mm 4: Can be combined with GN pinion motors of frame size 80 mm
②		LS: LS Linear Head
③	Traveling Direction of Rack	F: The rack travels vertically to the mounting flange B: The rack travels horizontally to the mounting flange
④	Basic Speed of Rack	10: 10 mm/s 20: 20 mm/s 45: 45 mm/s
⑤	Stroke	1: 100 mm 2: 200 mm 3: 300 mm 4: 400 mm 5: 500 mm 6: 600 mm 7: 700 mm 8: 800 mm 9: 900 mm 10: 1000 mm

LS Linear Heads

2LS Type

Maximum Transportable Mass: 30 kg

The maximum transportable mass varies with basic speed and the motor combined.

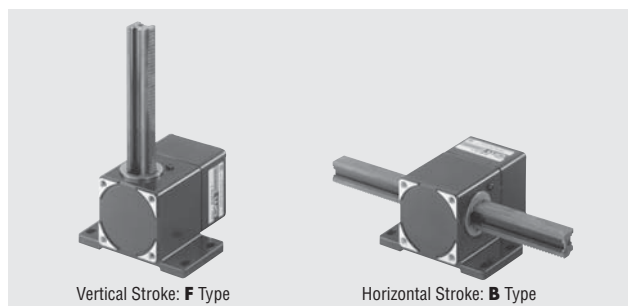

Vertical Stroke: **F** Type

Horizontal Stroke: **B** Type

Product Line

Model	Model	Model
2LS□10-1	2LS□20-1	2LS□45-1
2LS□10-2	2LS□20-2	2LS□45-2
2LS□10-3	2LS□20-3	2LS□45-3
2LS□10-4	2LS□20-4	2LS□45-4
2LS□10-5	2LS□20-5	2LS□45-5
2LS□10-6	2LS□20-6	2LS□45-6
2LS□10-7	2LS□20-7	2LS□45-7
2LS□10-8	2LS□20-8	2LS□45-8

The following items are included in each product.
Linear Head, Operating Manual

● Enter **F** or **B** (traveling direction of rack) in the box (□) within the model name.

Specifications

● Linear Head Specifications (RoHS)

Model	Vertical (F) Type	2LSF10-□	2LSF20-□	2LSF45-□
	Horizontal (B) Type	2LSB10-□	2LSB20-□	2LSB45-□
Basic Speed	mm/s	10	20	45
Stroke	mm	100, 200, 300, 400, 500, 600, 700, 800		

- Enter the stroke in the box (□) within the model name.
- Basic speed is reference value based on the motor synchronous speed (1500 r/min at 50 Hz).
The actual rack speed varies with the load and power supply frequency.

How to read specifications → Page D-95

● Permissible Rack Rotating Torque (Moment)

0.3 N·m or less

● Overrun

Refer to page F-57 of technical reference for overrun values.

● Maximum Permissible Overhung Load

Stroke mm	Max. Permissible Overhung Load N
100	55
200	40
300	30
400	25
500	20
600	15
700	12
800	8

Applicable Products

Application	Applicable Product		Single-Phase 200 VAC Type	Page
Constant speed	Reversible motor*	Lead wire type	2RK6GN-CW2E	A-68
		Terminal box type	2RK6GN-CW2BE	
Position holding	Electromagnetic brake motor*		2RK6GN-CW2ME	A-102
Variable speed	Speed control motor		ES02/2RK6RGN-CW2E	A-178
Pushing	Torque motor		2TK3GN-CW2E	A-223

* Single-phase 200 VAC type motors can be combined with the brake pack **SB50W** capable of instantaneous stop, bi-directional operation and electromagnetic brake control.
Brake Pack **SB50W** → Page A-143

- The characteristics when combined with applicable product can be found using the formula shown on "characteristics of lineard motors and linear heads." **Technical reference** → Page F-56
- In addition to the products shown above, the products for single-phase 110/115 VAC and three-phase 200/220/230 VAC products are also available. Please contact the nearest Oriental Motor sales office.

Note:

- When the decimal gearhead **2GN10XS** or **2GN10XK** is used, use the mounting screws included with the decimal gearhead.

Examples of Characteristics Combined with Each Motor

Reversible Motors

Applicable Motor		Linear Head Model		2LSF10-□, 2LSB10-□		2LSF20-□, 2LSB20-□		2LSF45-□, 2LSB45-□	
Motor Model	Power Supply Input		Max. Transportable Mass kg	Holding Force N	Max. Transportable Mass kg	Holding Force N	Max. Transportable Mass kg	Holding Force N	
	Voltage VAC	Frequency Hz							
2RK6GN-CW2E 2RK6GN-CW2BE	Single-Phase 230	50	30	81	19	33	10	16	
		60			15		9		

- Enter the stroke in the box (□) within the model name.
- The maximum load mass that can be driven when operating the rack vertically is the maximum transportable mass less the rack mass.
The holding force when operating the rack vertically is the holding force less the force calculated by 9.807 multiplying by rack mass.
- Holding force is provided by the built-in friction brake of the reversible motor. The values vary depending on the temperature and the time of operation (reference values).

Electromagnetic Brake Motor

Applicable Motor		Linear Head Model		2LSF10-□, 2LSB10-□		2LSF20-□, 2LSB20-□		2LSF45-□, 2LSB45-□	
Motor Model	Power Supply Input		Max. Transportable Mass kg	Holding Force N	Max. Transportable Mass kg	Holding Force N	Max. Transportable Mass kg	Holding Force N	
	Voltage VAC	Frequency Hz							
2RK6GN-CW2ME	Single-Phase 230	50	30	300	19	190	10	99	
		60			15		9		

- Enter the stroke in the box (□) within the model name.
- The maximum load mass that can be driven when operating the rack vertically is the maximum transportable mass less the rack mass.
The holding force when operating the rack vertically is the holding force less the force calculated by 9.807 multiplying by rack mass.
- When operating the mechanism horizontally supported the load by a guide, ensure that the load mass is less than the maximum transportable mass.

Speed Control Motors

Linear Head Model	Motor Model	Power Supply Input		Variable Speed Range mm/s (r/min)	Max. Transportable Mass		Holding Force N
		Voltage VAC	Frequency Hz		Set Speed mm/s (r/min)	Transportable Mass kg	
2LSF10-□ 2LSB10-□	ES02/ 2RK6RGN-CW2E	Single-Phase 230	50	0.6~9 (90~1400)	0.6 (90)	30	81
			60	0.6~10 (90~1600)	7.7 (1200)		
2LSF20-□ 2LSB20-□	ES02/ 2RK6RGN-CW2E	Single-Phase 230	50	1.4~22 (90~1400)	0.6 (90)	19	33
			60	1.4~25 (90~1600)	7.7 (1200)	17	
2LSF45-□ 2LSB45-□	ES02/ 2RK6RGN-CW2E	Single-Phase 230	50	2.8~44 (90~1400)	1.5 (90)	10	16
			60	2.8~50 (90~1600)	19 (1200)	9.8	

- Enter the stroke in the box (□) within the model name.
- The maximum load mass that can be driven when operating the rack vertically is the maximum transportable mass less the rack mass.
The holding force when operating the rack vertically is the holding force less the force calculated by 9.807 multiplying by rack mass.
- Holding force is provided by the built-in friction brake of the reversible motor. The values vary depending on the temperature and the time of operation (reference values).

Note:

- If the rack is moving up and down, speed control is disabled in downward moving. In these applications, use the full speed.

Decimal Gearhead

Even when using a decimal gearhead, the maximum transportable mass and holding force do not change.

Direction of Rack Movement

→Page D-122

Dimensions (Unit = mm)

Linear Heads

Model	Stroke mm	Total Length L mm	Mass (Rack mass included) kg	Rack Mass kg	When Limit Switch Installed	
					Effective Stroke mm	Total Mass kg
2LSF (B) □-1	100	229.4±0.4	1.3	0.5	100	1.5
2LSF (B) □-2	200	330±0.4	1.4	0.6	200	1.6
2LSF (B) □-3	300	430.4±0.4	1.6	0.8	300	1.8
2LSF (B) □-4	400	531±0.4	1.8	1.0	400	2.0
2LSF (B) □-5	500	631.5±0.4	2.0	1.2	500	2.2
2LSF (B) □-6	600	731.4±0.4	2.2	1.4	600	2.4
2LSF (B) □-7	700	829.5±0.4	2.4	1.6	700	2.6
2LSF (B) □-8	800	930.4±0.4	2.6	1.8	800	2.8

● Enter the basic speed in the box (□) within the model name.

● Limit switch set **PARP-MS** (sold separately) is available as an accessory. **Limit switch set** → Page D-125

Notes:

- The effective stroke refers to the maximum stroke over which the rack can travel when limit switches (sold separately) and dogs are used.
- If the work is installed on the limit switch side, the effective stroke becomes 15 mm shorter.
- If limit switches are not installed, the effective stroke becomes 60 mm longer.

◇ 2LSF Type Rack module 0.892 Pressure angle 20°

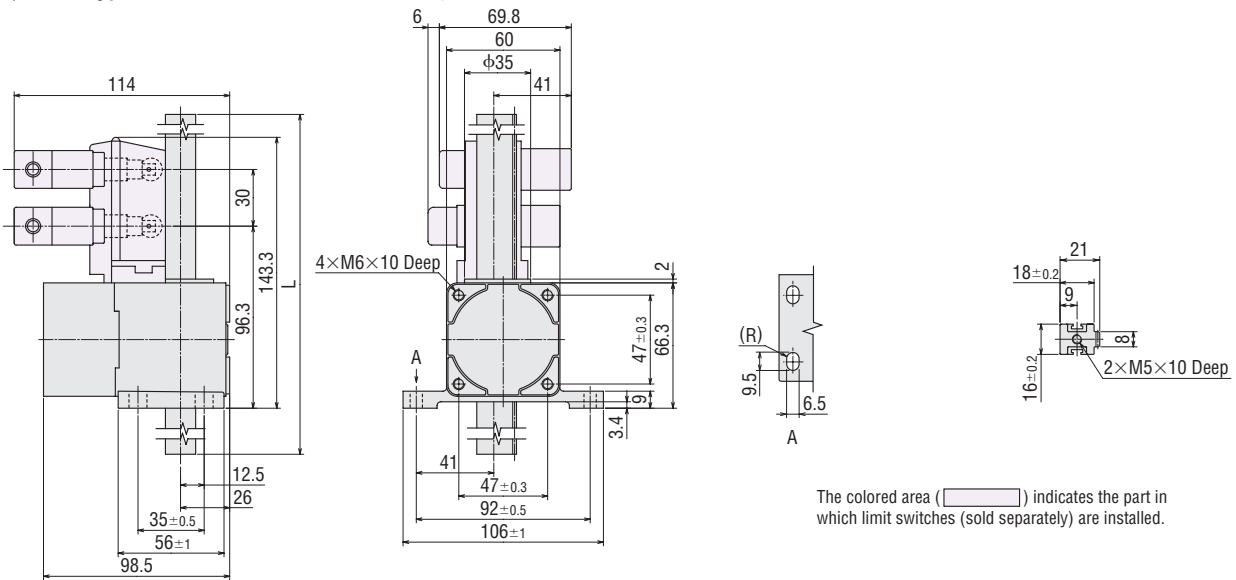

◇ 2LSB Type Rack module 0.892 Pressure angle 20°

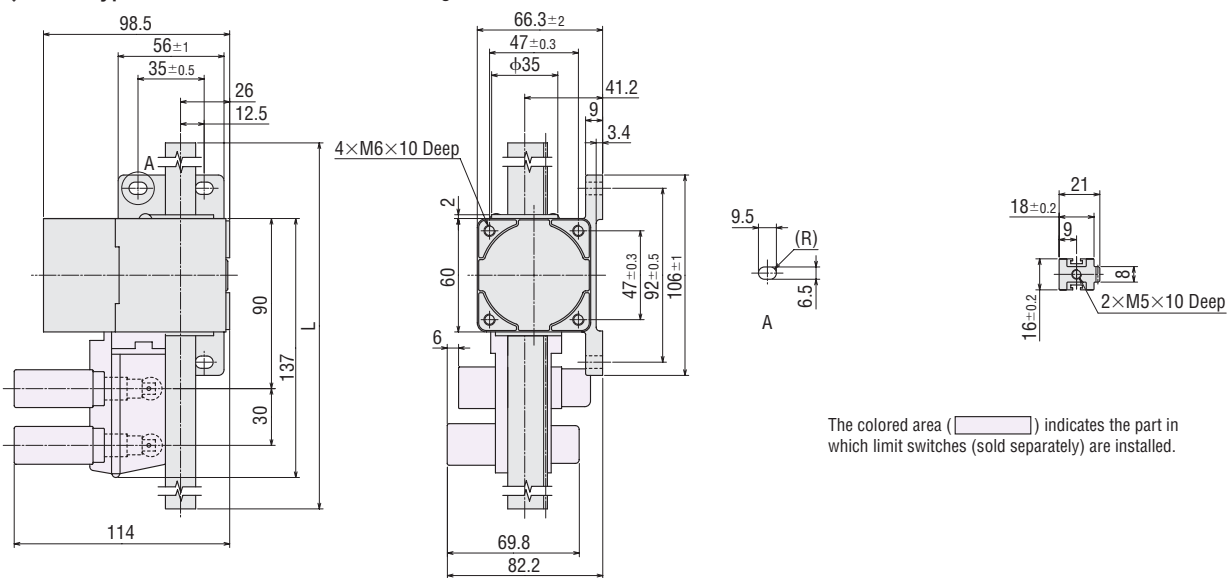

LS Linear Heads

4LS Type

Maximum Transportable Mass: 100 kg

The maximum transportable mass varies with basic speed and the motor combined.

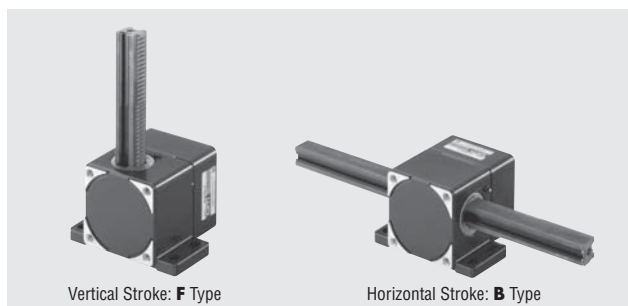
Vertical Stroke: **F** TypeHorizontal Stroke: **B** Type

Product Line

Model	Model	Model
4LS□10-1	4LS□20-1	4LS□45-1
4LS□10-2	4LS□20-2	4LS□45-2
4LS□10-3	4LS□20-3	4LS□45-3
4LS□10-4	4LS□20-4	4LS□45-4
4LS□10-5	4LS□20-5	4LS□45-5
4LS□10-6	4LS□20-6	4LS□45-6
4LS□10-7	4LS□20-7	4LS□45-7
4LS□10-8	4LS□20-8	4LS□45-8
4LS□10-9	4LS□20-9	4LS□45-9
4LS□10-10	4LS□20-10	4LS□45-10

● Enter **F** or **B** (traveling direction of rack) in the box (□) within the model name.

The following items are included in each product.
Linear Head, Operating Manual

Specifications

● Linear Head Specifications (RoHS)

Model	Vertical (F) Type	4LSF10-□	4LSF20-□	4LSF45-□
	Horizontal (B) Type	4LSB10-□	4LSB20-□	4LSB45-□
Basic Speed	mm/s	10	20	45
Stroke	mm	100, 200, 300, 400, 500, 600, 700, 800, 900, 1000		

● Enter the stroke in the box (□) within the model name.

● Basic speed is reference value based on the motor synchronous speed (1500 r/min at 50 Hz).

The actual speed varies with the load and power supply frequency.

How to read specifications → Page D-95

● Permissible Rack Rotating Torque (Moment)

0.5 N·m or less

● Overrun

Refer to page F-57 of technical reference for overrun values.

Applicable Products

Application	Applicable Product		Single-Phase 200 VAC Type	Page
Constant speed	Reversible motor*	Lead wire type	4RK25GN-CW2E	A-76
		Terminal box type	4RK25GN-CW2TE	
Position holding	Electromagnetic brake motor*		4RK25GN-CW2ME	A-110
Variable speed	Speed control motor		ES02/4RK25RGN-CW2E	A-178
Pushing	Torque motor		4TK10GN-CW2E	A-223

* Single-phase 200 VAC type motors can be combined with the brake pack **SB50W** capable of instantaneous stop, bi-directional operation and electromagnetic brake control.
Brake Pack **SB50W** → Page A-143

● The characteristics when combined with applicable product can be found using the formula shown on "characteristics of lineard motors and linear heads." **Technical reference** → Page F-56

● In addition to the products shown above, the products for single-phase 110/115 VAC and three-phase 200/220/230 VAC products are also available. Please contact the nearest Oriental Motor sales office.

Note:

● When the decimal gearhead **4GN10XS** or **4GN10XK** is used, use the mounting screws included with the decimal gearhead.

Examples of Characteristics Combined with Each Motor

Reversible Motors

Applicable Motor		Linear Head Model		4LSF10-□, 4LSB10-□		4LSF20-□, 4LSB20-□		4LSF45-□, 4LSB45-□	
Motor Model	Power Supply Input		Max. Transportable Mass kg	Holding Force N	Max. Transportable Mass kg	Holding Force N	Max. Transportable Mass kg	Holding Force N	
	Voltage VAC	Frequency Hz							
4RK25GN-CW2E 4RK25GN-CW2TE	Single-Phase 230	50	100	210	66	100	35	50	
		60			58		31		

- Enter the stroke in the box (□) within the model name.
- The maximum load mass that can be driven when operating the rack vertically is the maximum transportable mass less the rack mass.
The holding force when operating the rack vertically is the holding force less the force calculated by 9.807 multiplying by rack mass.
- Holding force is provided by the built-in friction brake of the reversible motor. The values vary depending on the temperature and the time of operation (reference values).

Electromagnetic Brake Motor

Applicable Motor		Linear Head Model		4LSF10-□, 4LSB10-□		4LSF20-□, 4LSB20-□		4LSF45-□, 4LSB45-□	
Motor Model	Power Supply Input		Max. Transportable Mass kg	Holding Force N	Max. Transportable Mass kg	Holding Force N	Max. Transportable Mass kg	Holding Force N	
	Voltage VAC	Frequency Hz							
4RK25GN-CW2ME	Single-Phase 230	50	100	1000	66	700	35	330	
		60			58		31		

- Enter the stroke in the box (□) within the model name.
- The maximum load mass that can be driven when operating the rack vertically is the maximum transportable mass less the rack mass.
The holding force when operating the rack vertically is the holding force less the force calculated by 9.807 multiplying by rack mass.
- When operating the mechanism horizontally supported the load by a guide, ensure that the load mass is less than the maximum transportable mass.

Speed Control Motors

Linear Head Model	Motor Model	Power Supply Input		Variable Speed Range mm/s (r/min)	Max. Transportable Mass		Holding Force N
		Voltage VAC	Frequency Hz		Set Speed mm/s (r/min)	Transportable Mass kg	
4LSF10-□ 4LSB10-□	ES02/ 4RK25RGN-CW2E	Single-Phase 230	50	0.7~10 (90~1400)	0.7 (90)	90	210
			60		0.7~11 (90~1600)	8.9 (1200)	
			50	1.4~20 (90~1400)		0.7 (90)	
			60		1.4~23 (90~1600)	8.9 (1200)	
4LSF20-□ 4LSB20-□	ES02/ 4RK25RGN-CW2E	Single-Phase 230	50	1.4~20 (90~1400)		1.4 (90)	47
			60		1.4~23 (90~1600)	18 (1200)	64
			50	2.8~43 (90~1400)		1.4 (90)	45
			60		2.8~49 (90~1600)	18 (1200)	58
4LSF45-□ 4LSB45-□	ES02/ 4RK25RGN-CW2E	Single-Phase 230	50	2.8~43 (90~1400)		2.8 (90)	25
			60		2.8~49 (90~1600)	37 (1200)	34
			50	2.8~49 (90~1600)		2.8 (90)	24
			60		2.8~49 (90~1600)	37 (1200)	30

- Enter the stroke in the box (□) within the model name.
- The maximum load mass that can be driven when operating the rack vertically is the maximum transportable mass less the rack mass.
The holding force when operating the rack vertically is the holding force less the force calculated by 9.807 multiplying by rack mass.
- Holding force is provided by the built-in friction brake of the reversible motor. The values vary depending on the temperature and the time of operation (reference values).

Note:

- If the rack is moving up and down, speed control is disabled in downward moving. In these applications, use the full speed.

Decimal Gearhead

Even when using a decimal gearhead, the maximum transportable mass and holding force do not change.

Direction of Rack Movement

→ Page D-122

Dimensions (Unit = mm)

Linear Heads

Model	Stroke mm	Total Length L mm	Mass (Rack mass included) kg	Rack Mass kg	When Limit Switch Installed	
					Effective Stroke mm	Total Mass kg
4LSF (B) □-1	100	243.5±0.4	1.9	0.7	95	2.1
4LSF (B) □-2	200	341.6±0.4	2.2	1.0	195	2.4
4LSF (B) □-3	300	443.7±0.4	2.5	1.3	295	2.7
4LSF (B) □-4	400	541.9±0.4	2.7	1.5	395	2.9
4LSF (B) □-5	500	640.1±0.4	3.0	1.8	495	3.2
4LSF (B) □-6	600	742.2±0.4	3.3	2.1	595	3.5
4LSF (B) □-7	700	840.4±0.4	3.6	2.4	695	3.8
4LSF (B) □-8	800	942.5±0.4	3.9	2.7	795	4.1
4LSF (B) □-9	900	1040.7±0.8	4.2	3.0	895	4.4
4LSF (B) □-10	1000	1142.8±0.8	4.5	3.3	995	4.7

- Enter the basic speed in the box (□) within the model name.
- Limit switch set **PARP-MS** (sold separately) is available as an accessory. **Limit switch set** → Page D-125

Notes:

- The effective stroke refers to the maximum stroke over which the rack can travel when limit switches (sold separately) and dogs are used.
- If the work is installed on the limit switch side, the effective stroke becomes 15 mm shorter.
- If limit switches are not installed, the effective stroke becomes 55 mm longer.

◇ 4LSF Type Rack module 1.25 Pressure angle 20°

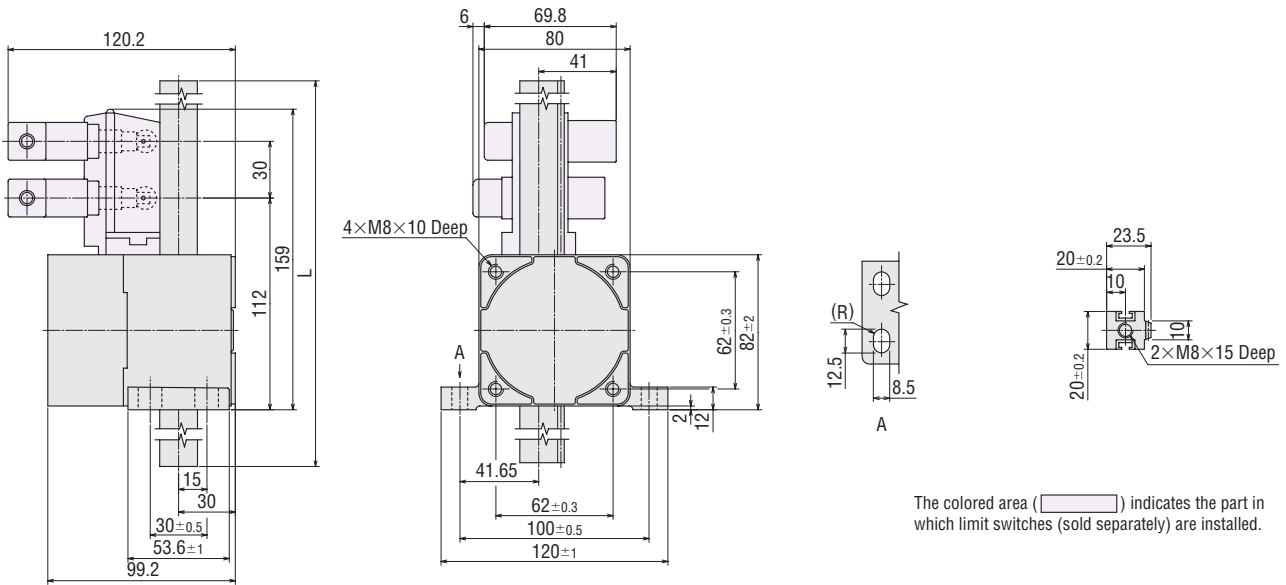

◇ 4LSB Type Rack module 1.25 Pressure angle 20°

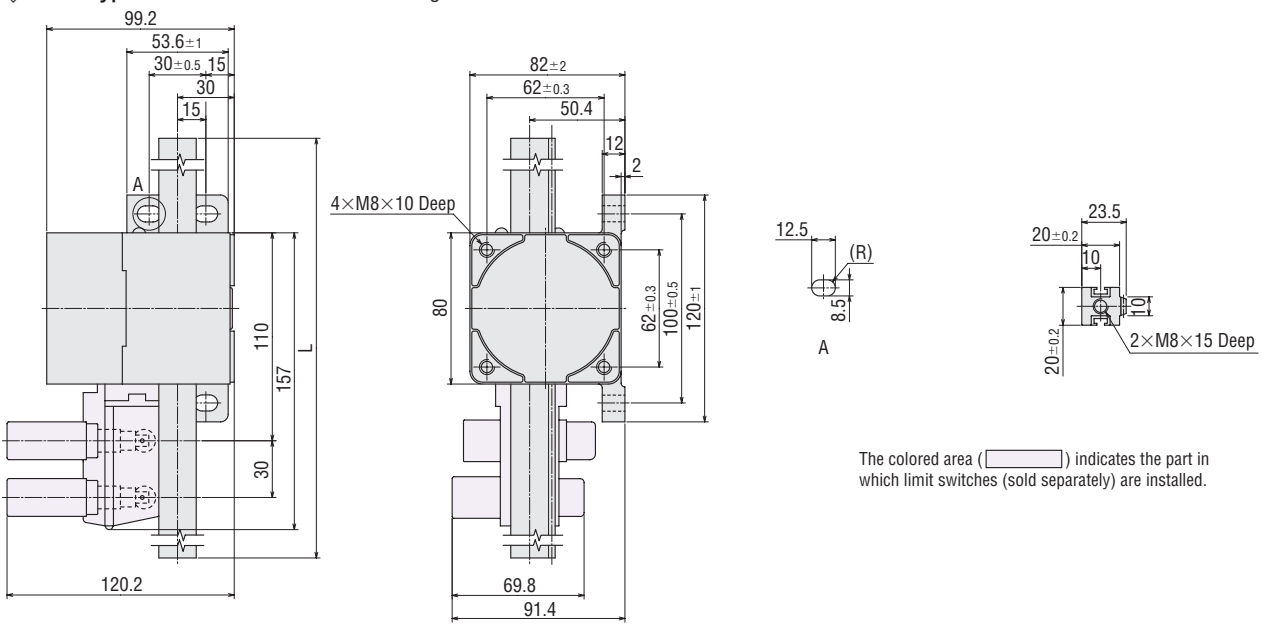

Direction of Rack Movement

The direction of rack movement is determined by the rotation direction of motor.

2LS Type

Model	Rotation Direction of Motor	
	Clockwise	Counterclockwise
2LSF10 -□	Down	Up
2LSF45 -□	Down	Up
2LSB10 -□	Left	Right
2LSB45 -□	Left	Right
2LSF20 -□	Up	Down
2LSB20 -□	Right	Left

4LS Type

Model	Rotation Direction of Motor	
	Clockwise	Counterclockwise
4LSF10 -□	Up	Down
4LSF20 -□	Up	Down
4LSB10 -□	Right	Left
4LSB20 -□	Right	Left
4LSF45 -□	Down	Up
4LSB45 -□	Left	Right

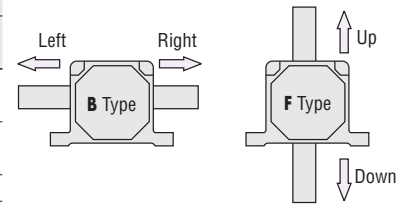

- Enter the stroke in the box (□) within the model name.
- Direction of rack movement is viewed from the linear head side.
- Even when using a decimal gearhead, the direction of rack movement does not change.

Connection Diagram

Connection Example Using Limit Switches (Sold separately)

Shown below is an example of combining **2LSB10**-□ with the electromagnetic brake motor **2RK6GN-CW2ME**. The direction of rack movement is viewed from the surface where the motor is assembled.

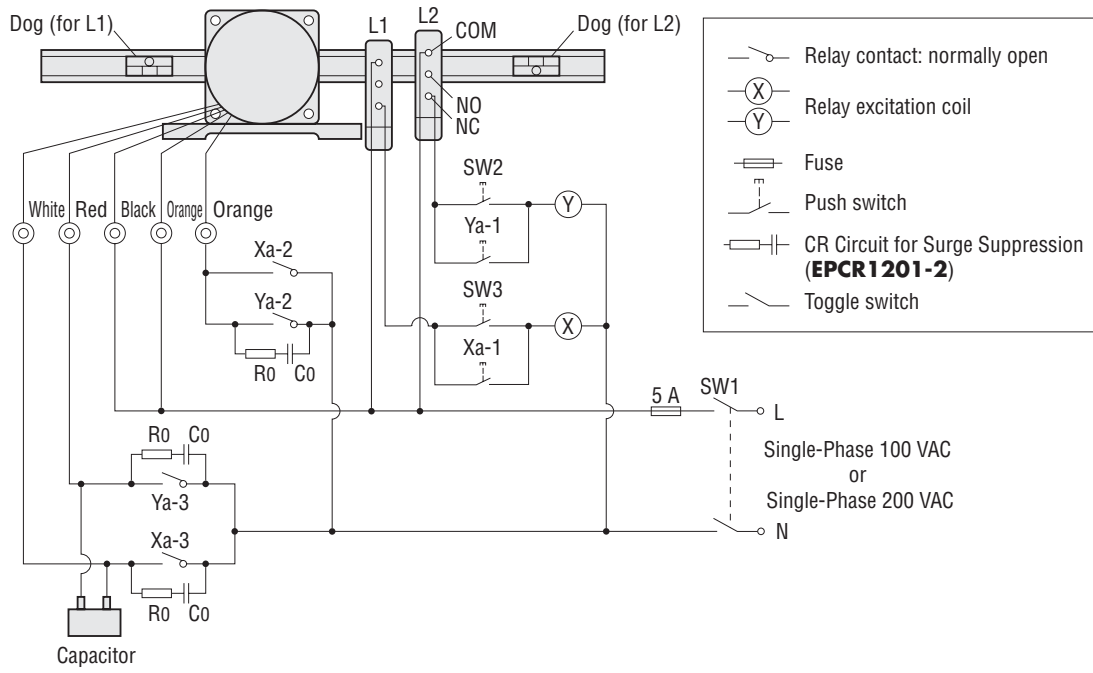

- SW1: Power supply
- SW2: Starts operation in right direction
- SW3: Starts operation in left direction
- L1: Stop signal in left direction
- L2: Stop signal in right direction
- Xa-1: For holding X
- Xa-2: For brake operation
- Xa-3: For rack operation in left direction
- Ya-1: For holding Y
- Ya-2: For brake operation
- Ya-3: For rack operation in right direction

- The contact capacity of each relay or switch should be at least 125 VAC 5 A or 250 VAC 5 A.

Rack and Pinion Systems Accessories (Sold separately)

For LAS Series

Motor Cables (RoHS)

Various cables that are useful for connecting motors and drivers are available.

Extension Cables/

Extension Cables for Electromagnetic Brake Motor

Extension cable for extending the wiring distance between the lineared motor and driver.



Product Line

Extension Cables

Model	Length L (m)
CC01AIP	1
CC02AIP	2
CC03AIP	3
CC05AIP	5
CC07AIP	7
CC10AIP	10
CC15AIP	15
CC20AIP	20

Extension Cables for Electromagnetic Brake Motor

Model	Length L (m)
CC01AIPM	1
CC02AIPM	2
CC03AIPM	3
CC05AIPM	5
CC07AIPM	7
CC10AIPM	10
CC15AIPM	15
CC20AIPM	20

Note:

- Electromagnetic brake models must use an extension cable for an electromagnetic brake motor.

Dimensions (Unit = mm)

◇ For Standard Model

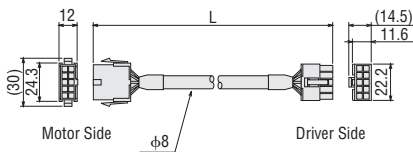

◇ For Electromagnetic Brake Model

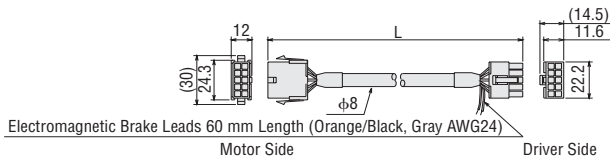

Flexible Extension Cables/

Flexible Extension Cables for Electromagnetic Brake Motor

Flexible extension cable for connecting a lineared motor and driver. Use flexible extension cable in application where the motor is installed on a moving section and the cable is bent and flexed.



Product Line

Flexible Extension Cables

Model	Length L (m)
CC01SAR	1
CC02SAR	2
CC03SAR	3
CC05SAR	5
CC07SAR	7
CC10SAR	10

Flexible Extension Cables for Electromagnetic Brake Motor

Model	Length L (m)
CC01SARM2	1
CC02SARM2	2
CC03SARM2	3
CC05SARM2	5
CC07SARM2	7
CC10SARM2	10

Note:

- Electromagnetic brake models must use an extension cable for an electromagnetic brake motor.

Dimensions (Unit = mm)

◇ For Standard Model

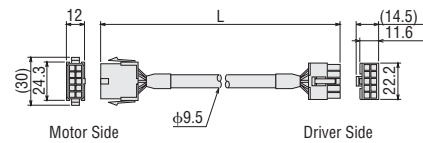

◇ For Electromagnetic Brake Model

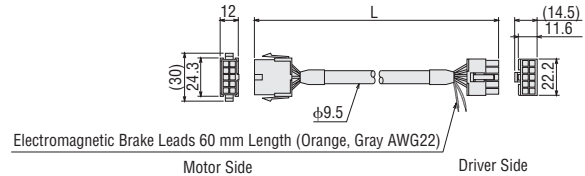

Notes on Use of a Flexible Extension Cable

- ① Do not allow the cable to bend at the cable connector.

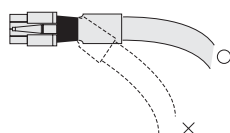

- ② Keep the bending radius to 60 mm or more.

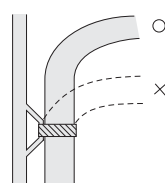

- ③ The motor cable is not a flexible cable. If the motor cable is to be bent, bend it at the flexible extension cable.

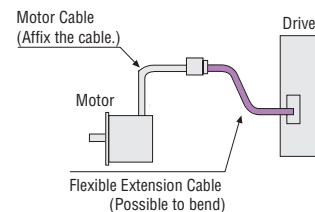

Driver Cables (RoHS)

This is a shielded cable useful for connecting a driver and controller.

Driver Cables General-Purpose Type

This is a shielded cable equipped with, at one end of the cable, the half-pitch connector that snaps into the driver.

Notes:

- Note that as the length of the pulse signal line between the driver and controller increases, the maximum transmission frequency decreases. **Technical reference** → Page F-57
- Install a connector that matches the controller you are using to the other end of the cable.

Product Line

Model	Length L (m)
CC36D1-1	1
CC36D2-1	2



Dimensions (Unit = mm)

Conductor: AWG28 (0.08 mm²)

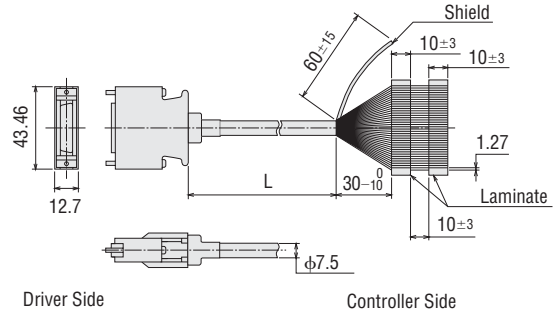

Connector-Terminal Block Conversion Unit (RoHS)

A conversion unit that connects a driver to a host controller using a terminal block.

- With a signal name plate for easy, one-glance identification of driver signal names
- DIN-rail mountable
- Cable length: 1 m

Product Line

Model	Length L (m)
CC36T1	1



Dimensions (Unit = mm)

CC36T1

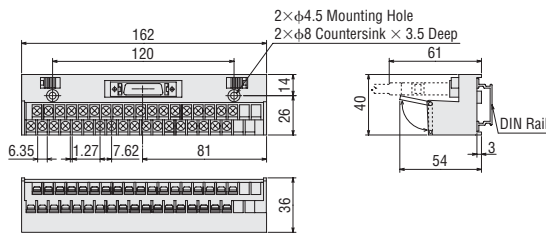

Terminal Block Pin Numbers

19	20	21	22	23	24	25	26	27	28	29	30	31	32	33	34	35	36		
1	2	3	4	5	6	7	8	9	10	11	12	13	14	15	16	17	18		

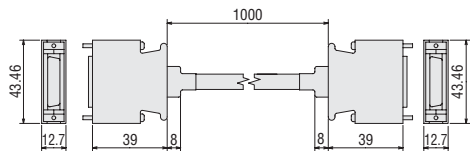

Recommended Crimp Terminal

- Terminal screw size: M3
- Tightening torque: 1.2 N·m
- Applicable minimum lead wire: AWG22 (0.3 mm²)

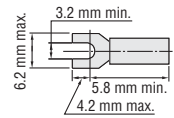

DIN Rail Mounting Plate (RoHS)

This plate is used to install the driver to a DIN rail. Mounting screws are included.

● Model: **PADPO1**

● Dimensions (Unit = mm)

Mass: 20 g

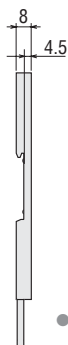
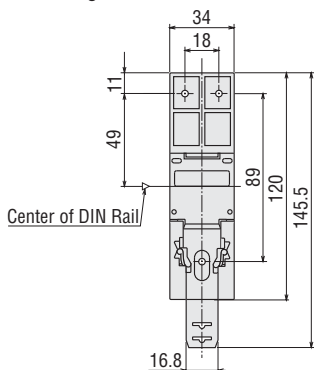

● Mounting Screw: M3
Length: 8 mm
3 included

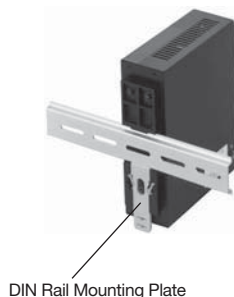

DIN Rail Mounting Plate

For LS Linear Heads

Limit Switch Set (RoHS)

These dedicated limit switches can be installed easily in **LS** linear heads.

With the limit switches, reciprocating operation can be performed easily.

Each set consists of two limit switches, four dogs, limit-switch mounting brackets and covers.

● Model: **PARP-MS**

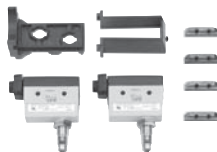

● Specifications

Rated Voltage	Motor Load	Inductive Load
125 VAC	2.5 A	10 A
250 VAC	1.4 A	10 A
125 VDC	0.05 A	0.05 A

● Permissible operation frequency: 20 times/minute

● Life : At least 500000 times

● Linear head with limit switches

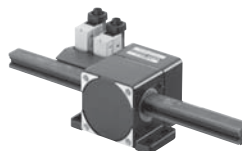

Dog (RoHS)

Use extra dogs if the dogs included with the limit switch set are not enough to implement the required multiple-point stop operation etc.

● Model: **LXDT-4** (4 included)

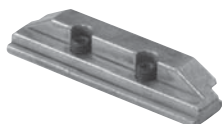

● Dimensions (Unit = mm)

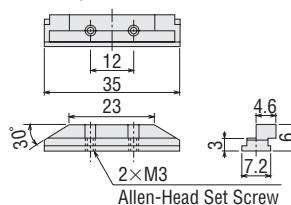

CR Circuit for Surge Suppression (RoHS)

This circuit is used to absorb surge voltage and protect the relay contacts.

● Model: **EPCR1201-2**

250 VAC (120 Ω, 0.1 μF)

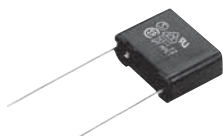

● Dimensions (Unit = mm)

Mass: 5 g

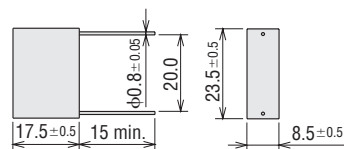

Rack and Pinion Systems Installation

Linear Head and Lineared Motor Installation

Installation Direction of Linear Head and Lineared Motor

There are no restrictions on the installation direction of linear head and lineared motor.

Mounting Method

- Secure the linear head or lineared motor firmly on a metal plate.
- Make a mounting hole or tapped hole on the mounting plate.
- For **F** type (vertical stroke), make an additional hole for the rack.
- Using the 4 mounting holes on the mounting surface of linear head or lineared motor, secure the linear head or lineared motor with 4 screws so that there is no gap between the linear head or lineared motor and the metal plate. (Mounting screws are not included.)

Installing with Mounting Flange

For **B** Type

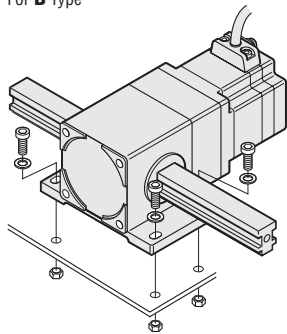

For **F** Type

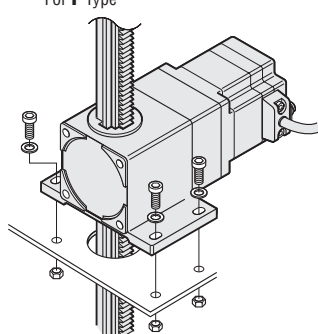

Installing with Front Mounting Holes

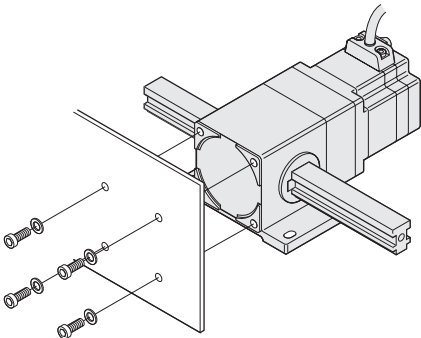

Installation Conditions

Linear heads, lineared motors and drivers are designed and manufactured to be mounted in a machine.

Make sure the installation location meets the following conditions as well-ventilated space with easy access for inspection.

- Inside an enclosure installed indoors (with ventilation holes provided)
- Ambient temperature: $-10\sim+50^{\circ}\text{C}$ (non-freezing)
 - (**LS** Linear Head),
 - $0\sim+50^{\circ}\text{C}$ (non-freezing)
 - (**LAS** Series)
- Ambient humidity: 85% or less (non-condensing)
- Not exposed to an explosive atmosphere, toxic gases (sulfurized gases etc.) or liquid
- Not exposed to direct sunlight
- Not exposed to significant amounts of dust or iron powder
- Not directly exposed to water or oil
- Not exposed to air having high salt content
- Not exposed to continuous vibration or excessive impact
- Not subjected to significant electromagnetic noise caused by welding machines, power equipment, etc.
- Not exposed to radioactive materials, magnetic field or vacuum conditions

Precautions in Handling

Rack Lubrication

A lubricating agent is necessary to prevent friction when the rack passes through the rack grommet. The surface of the rack and any gears that mesh with the pinion should always be kept lubricated. Since the rack case is filled with a lubrication agent, there is no need to lubricate the rack case. However, ensure that the surface of the rack or gear teeth do not become dry, as operating in this condition will shorten the product's life. When a rack is used vertically, or under high ambient temperature, the separated grease may drip. If the drip is a problem, take measures such as putting a saucer under the rack.

Precautions for Installation

Connecting Linear Heads to Motors

As the figure below shows, a linear head is combined with a motor using the pilots on each unit as guides. The linear head should be moved gently from side to side without forcing the pinion shaft against the gear of linear head. Please note that an attempting to put a motor and linear head together by force can result in damage to the tooth surface, causing strange noise.

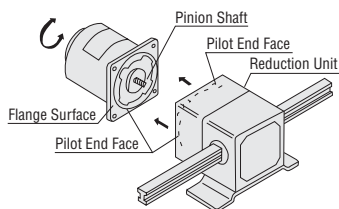

Mounting the Load to End of Rack

When mounting the load using the tapped hole on the end of the rack, hold the flat face of the rack rather than the toothed surface with a wrench while tightening the screw so that a rotational force is not applied to the rack. Note that the installation of the load with a rotational force applied to the rack can result in damage to the product.

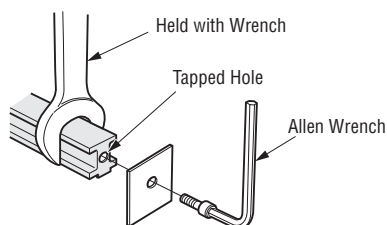

Precautions for Operation

Do Not Hit to Stop the Rack

Despite differences in control methods, rack and pinion systems are all moved by controlling motor.

Do not hit to stop the operation at the end of the rack. Using like this, the motor will apply not only excessive torque but also an inertial shock to the rack-and-pinion section, as a result, the gear will be damaged.

Do Not Exceed the Maximum Transportable Mass

The maximum transportable mass of each product is determined. Generally, the lower the motor's basic speed, the greater the maximum transportable mass becomes. If a load greater than this value is applied, or rack movement is locked for a long time, it is likely to result in damage to the rack-and-pinion section.

Use an Electromagnetic Brake Model for Vertical Operation

Use an electromagnetic brake model that can hold the load for vertical operation. The electromagnetic brakes that can be combined with linear heads, are power off activated type that are engaged in the event of a power failure and generate large holding force.

The combination of a reversible motor has a certain amount of holding force, but the brake force is limited and unsuitable for load holding at vertical operation.

Following electromagnetic brake models are available.

- LAS** Series with electromagnetic brake
- LS** linear head and motor with electromagnetic brake

For the **LAS** Series, when the driver's protective function has been activated, the current to the lineared motor is cut off to stop the motor. Make sure you provide a sequence for your controller to cut the power to the electromagnetic brake and hold the rack when the alarm output is detected.

Connecting for LAS Series with Electromagnetic Brake

Be sure to use extension cables for electromagnetic brake motor (accessory) when connecting lineared motor with electromagnetic brake and driver. If you connect the motor cable directly to the driver, the electromagnetic brake will not be activated.

The electromagnetic brake operates with the turning on/off of the DC power supply. Connect the electromagnetic brake leads from the extension cable while ensuring the correct polarity, and be sure to connect surge suppressor included to protect switch contact and suppress noise.

Driver Installation

Mounting Direction and Method

Box Type

◇ Installing Using the Mounting Bracket

1. Install a mounting bracket at the back of the driver using screws included.
2. Install the driver using the mounting holes of mounting bracket so that there is no gap between the driver and the metal plate.

Applicable Product:

LAS Series

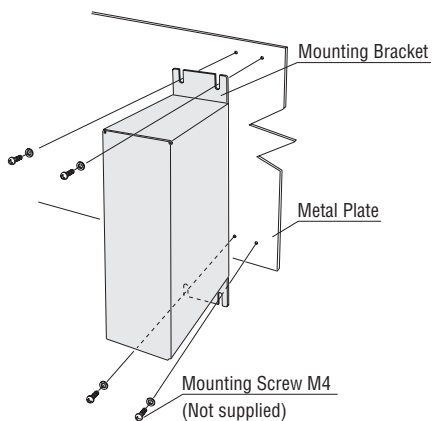

Notes:

- Firmly install on a metal plate that has good heat conductivity, such as iron or aluminum of 2 mm or more in thickness.
- To directly install the driver without using the mounting bracket included, pay particular attention to the length of the screws used for the mounting holes.

◇ Installing in a DIN Rail [Using a DIN rail mounting plate (Sold separately)]

Pull the DIN lever down, hook the top of the DIN rail mounting plate to the DIN rail, and press it down until the DIN lever is locked into place.

Applicable Product:

LAS Series

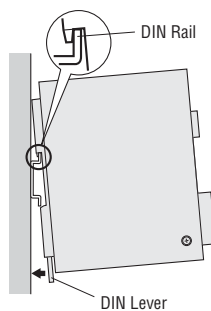

Notes:

- Use a DIN rail with a rail width of 35 mm and an end plate.
- The DIN rail and end plate are not included with the driver. Those must be purchased separately.

◇ Installation Clearances

When using multiple driver, driver temperature rise will cause ambient temperature to rise. At least 20 mm must be allowed between driver units and at least 25 mm between drivers and other equipment or structures.

Install a forced-air cooling fan if ambient temperature exceed 50°C.

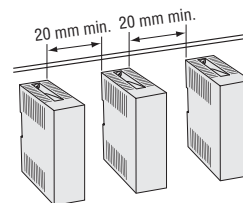

● Installation Conditions

Install the driver in a location that meets the following conditions, or the product may be damaged.

- Indoors (This product is designed and manufactured to be installed within another device.)
- Ambient temperature: 0~+50°C (non-freezing) (**LAS series**)
- Ambient humidity: 85% or less (non-condensing)
- Not exposed to explosive, flammable or corrosive gases
- Not exposed to direct sunlight
- Not exposed to dust
- Not directly exposed to water or oil
- A place where heat can escape easily
- Not exposed to continuous vibration or excessive impact

Notes:

- When installing the driver in an enclosed space such as a control box, or somewhere close to a heat-radiating object, vent holes should be used to prevent the driver from overheating.
- Do not install the driver in a location where a source of vibration will cause the driver to vibrate.
- In situations where drivers are located close to a large noise source such as high frequency welding machines or large electromagnetic switches, take steps to prevent noise interference, either by inserting noise filters or connecting the driver to a separate circuit.
- Take care that pieces of conductive material (filings, pins, pieces of wire, etc.) do not enter the drivers.