

## UCD1/7; UCD2/8

Dimensions (mm)	∅ 28 x 24
Step angle (°)	7,5
Holding torque * (cNm)	1.6–2.7
Detent torque (cNm)	0,26–0,42
Winding	bipolar/unipolar
Gear combination	on request



\* values for lead wire version (connection N) / connector versions up to 15 % higher

### Standard Data

Climatic class	wide-spread according to DIN IEC 60721-2-1
Ambient temperature operation	°C -15 ... +60
Ambient temperature storage	°C -20 ... +100
Thermal resistance at f=0 R <sub>therm</sub>	29 K/W
Thermal class	B according to DIN EN 60085
Approval	standard
Mounting	any position
Electrical connection	connector type D or N
Protection	IP 30 according to DIN EN 60529
Weight	54 g
Rotor stalling	motor can be stopped when voltage is applied, without being overheated
Bearings	Sintered bronze, self-lubricating

### Order Reference

Type	Stepper Motor		UCD	1	0	N	24 Ω	R	B
Configuration	1	bipolar, standard magnet	7	bipolar, stronger magnet					
	2	unipolar, standard magnet	8	unipolar, stronger magnet					
Rotor shaft, mounting	3	centring 8 mm, shaft 2,0 mm, screw plate	E	centring 10 mm, shaft 2,0 mm, screw plate					
	4	centring 8 mm, shaft 1,5 mm, screw plate	K	centring 10 mm, shaft 1,5 mm, screw plate					
	0	centring 8 mm, shaft 2,0 mm, clip	A	centring 10 mm, shaft 2,0 mm, clip					
	1	centring 8 mm, shaft 1,5 mm, clip	C	centring 10 mm, shaft 1,5 mm, clip					
Approval	N	Approval Standard							
Resistance	see next pages; Resistance per winding for bipolar or unipolar								
Direction	R	reversible							
Connection	D	see next pages „Connection Types“							
	N								

## Technical Data

		UCD1		UCD5	
bipolar	Holding torque $M_H$ *	cNm	2		2.7
	Detent torque $M_S$	cNm	0,26		0,42
	Rotor inertia $J_R$	gcm <sup>2</sup>	2.2		2.4
	Rated voltage $U_N$	V	6	12	24
	Resistance per winding $R_{20}$	$\Omega$	24	90	380
	Steps per revolution		48		
	Duty cycle		100%		
	Direction of rotation	V	reversible		
<hr/>					
		UCD2		UCD6	
unipolar	Holding torque $M_H$	cNm	1,6		2,3
	Detent torque $M_S$	cNm	0,26		0,42
	Rotor inertia $J_R$	gcm <sup>2</sup>	2.2		2.4
	Rated voltage $U_N$	V	3	6	24
	Resistance per winding $R_{20}$	$\Omega$	24	90	380
	Steps per revolution		48		
	Duty cycle		100%		
	Direction of rotation	V	reversible		

\* values for lead wire version (connection N) / connector versions up to 15 % higher

Circuit diagram bipolar

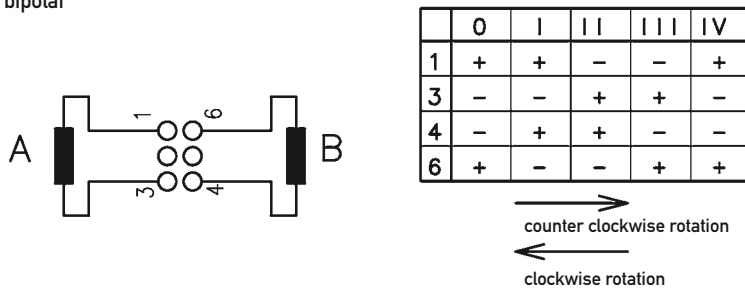

Circuit diagram unipolar

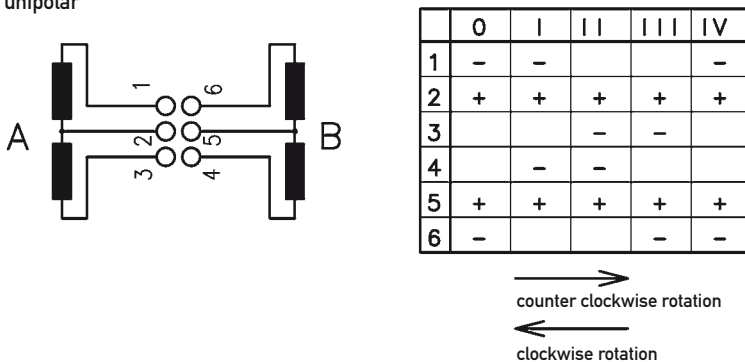

## Dimensions Version with Connector D

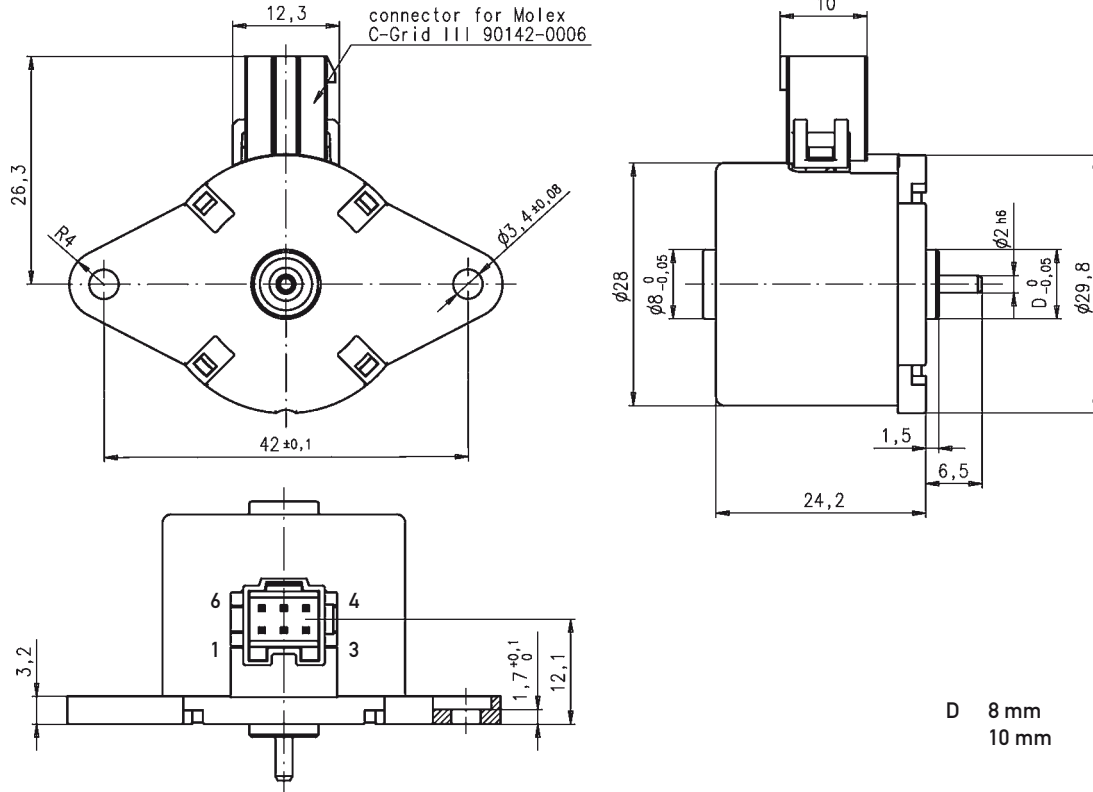

## Version with Connector N

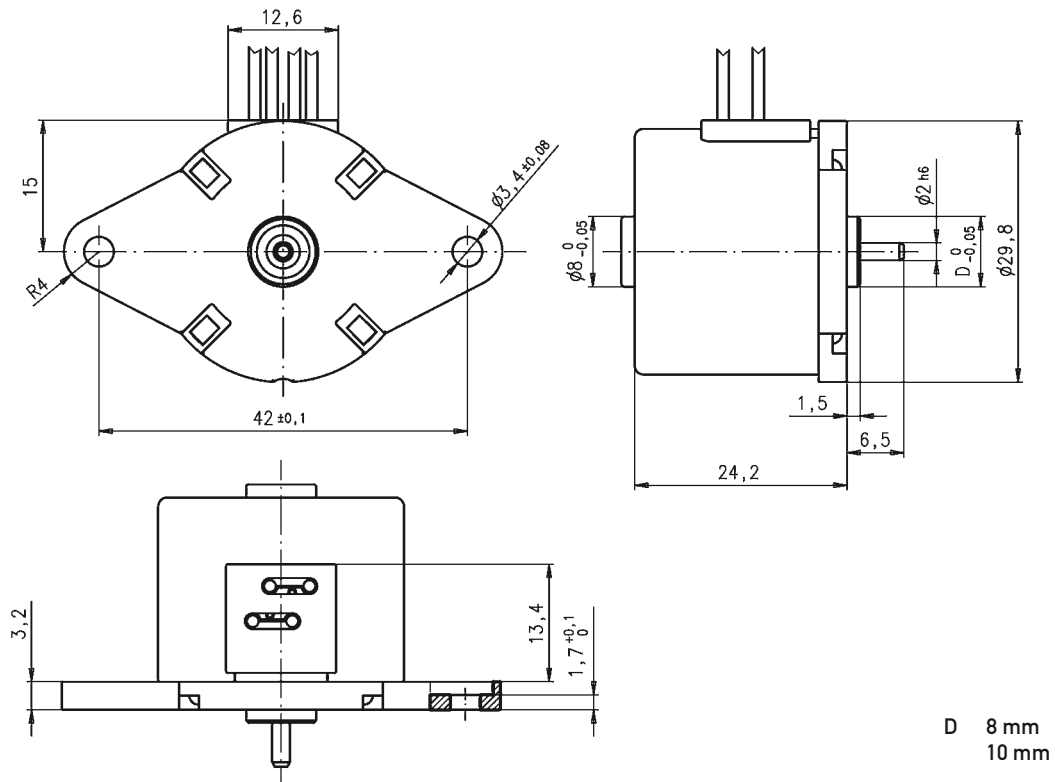

## Performance Chart

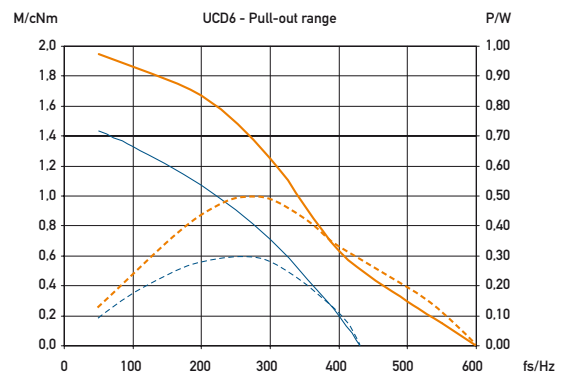
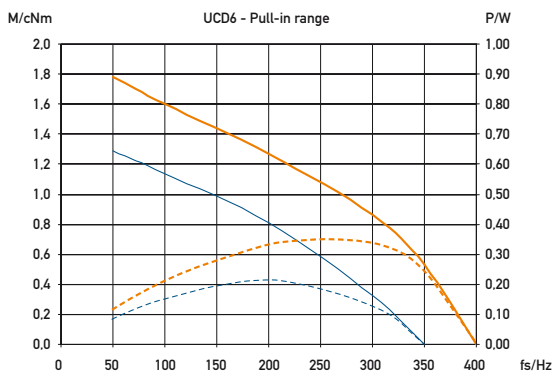
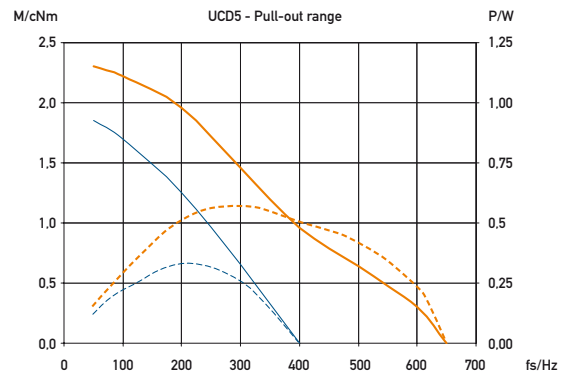
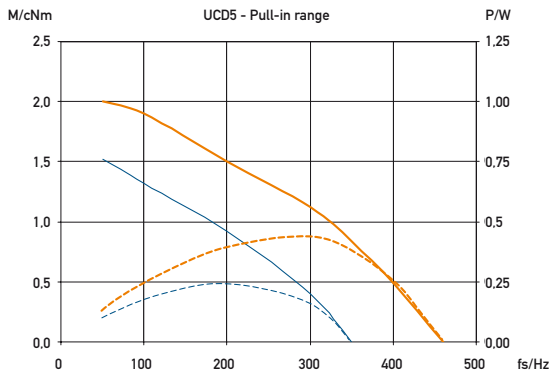
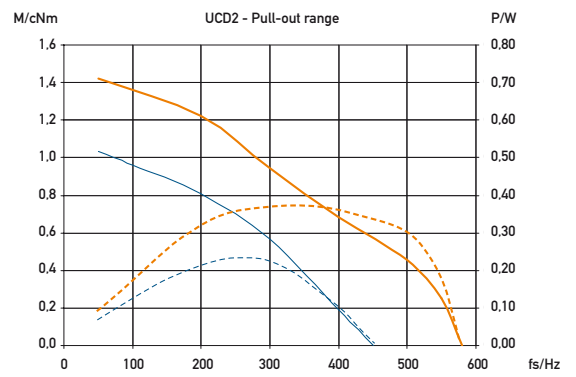
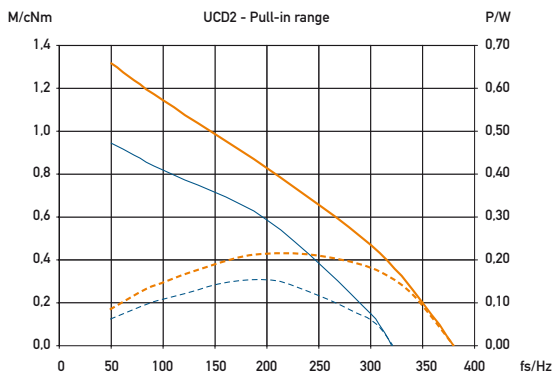
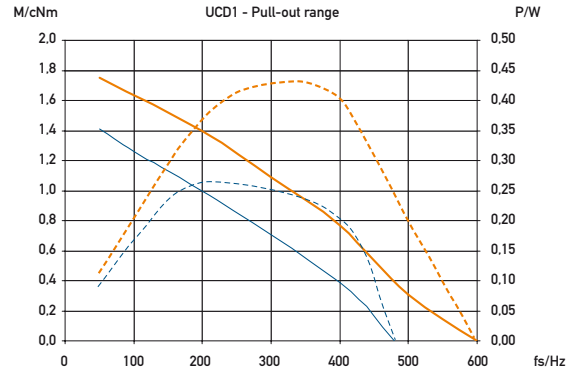
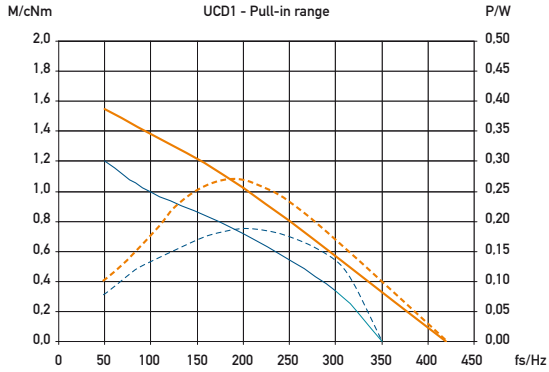

— M - Duty cycle 30 %  
— M - Duty cycle 100%

- - - P - Duty cycle 30 %  
- - - P - Duty cycle 100%